

RYOBI®

EMBS200

MINI BELT & DISC SANDER OWNER'S OPERATION MANUAL

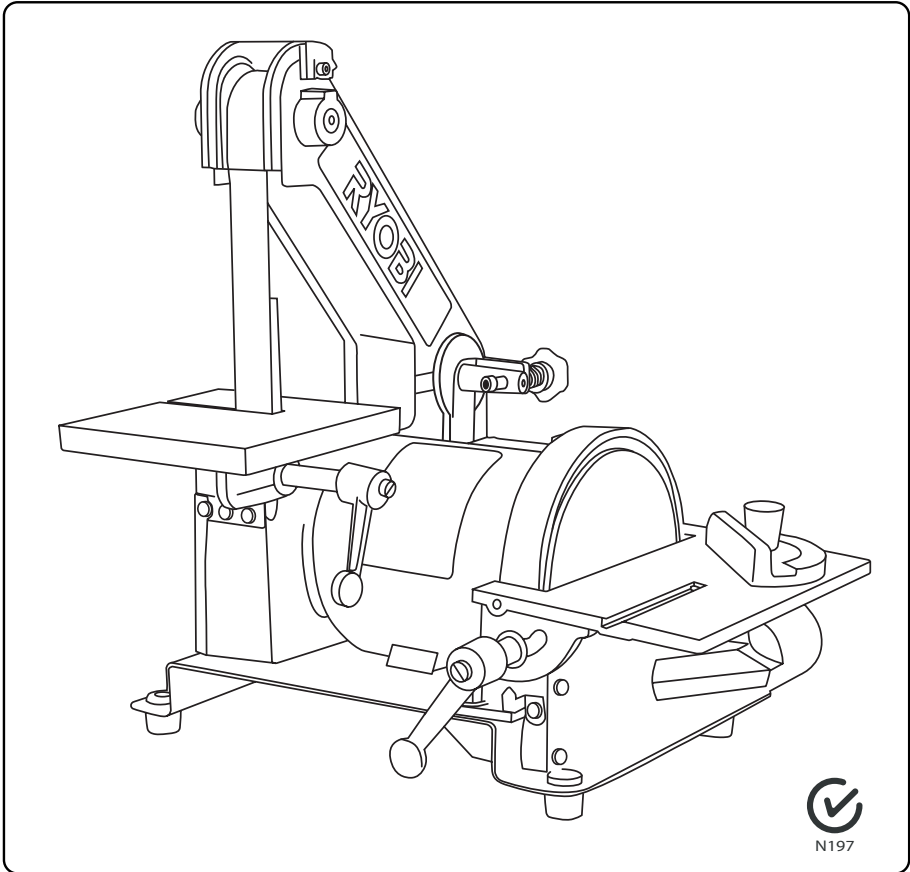

TABLE OF CONTENTS

■ Table of Contents	1
■ Product Specifications	1
■ Rules for Safe Operation	2-4
■ Unpacking	5
■ Loose Parts List	5
■ Features	6-7
■ Assembly	8-10
■ Operation	11
■ Maintenance	12
■ Trouble Shooting	13
■ Notes	14

PRODUCT SPECIFICATIONS

Model Number	EMBS200
Input	200 Watt
Disc Speed	3600 rpm
Belt Speed	970m/min
Disc Diameter	125mm
Belt Dimensions	25 x 762mm
Disc Table Size	95 x 180mm
Belt Table Size	125 x 125mm
Weight	8kg



Look for this symbol to point out important safety precautions.
It means attention!!! Your safety is involved.

RULES FOR SAFE OPERATION

Safe operation of this tool stand requires that you read and understand this operator's manual and any labels affixed to the tool. Safety is a combination of common sense and staying alert.

READ ALL INSTRUCTIONS

- **KNOW YOUR POWER TOOL.** Read the operator's manual carefully. Learn the applications and limitations as well as specific potential hazards related to this tool.
- **GUARD AGAINST ELECTRICAL SHOCK** by preventing body contact with grounded surfaces. For example: pipes, radiators, ranges, refrigerator enclosures.
- **KEEP GUARDS IN PLACE** and in working order. Never operate the tool with any guard or cover removed. Make sure all guards are operating properly before each use.
- **REMOVE ADJUSTING KEYS AND WRENCHES.** Form habit of checking to see keys and adjusting wrenches are removed from tool before turning it on.
- **KEEP THE WORK AREA CLEAN.** Cluttered work areas and work benches invite accidents.
- **AVOID DANGEROUS ENVIRONMENTS.** Do not use power tools near gasoline or other flammable liquids, in damp or wet locations or expose them to rain. Keep work area well lighted.
- **KEEP CHILDREN AND VISITORS AWAY.** All visitors should wear safety glasses and be kept a safe distance from work area.
- **MAKE WORKSHOP CHILD PROOF** with padlocks, master switches, or by removing starter keys.
- **DON'T FORCE THE TOOL.** It will do the job better and safer at the rate for which it was designed.
- **USE THE RIGHT TOOL.** Do not force the tool or attachment to do a job for which it was not designed.
- **USE THE PROPER EXTENSION CORD.** Make sure your extension cord is in good condition. When using an extension cord, be sure to use one heavy enough to carry the current your product will draw. An undersized cord will cause a drop in line voltage resulting in loss of power and overheating. A wire gauge size (A.W.G.) of at least 16 is recommended for an extension cord 8 metres or less in length. If in doubt, use the next heavier gauge. The smaller the gauge number, the heavier the cord.
- **INSPECT EXTENSION CORDS PERIODICALLY** and replace if damaged.
- **WEAR PROPER APPAREL.** Do not wear loose clothing, neckties, or jewelry that can get caught in the tool's moving parts and cause personal injury. Nonslip footwear is recommended when working outdoors. Wear protective hair covering to contain long hair.
- **ALWAYS WEAR SAFETY GLASSES WITH SIDE SHIELDS.** Everyday eyeglasses have only impact-resistant lenses; they are NOT safety glasses.
- **PROTECT YOUR LUNGS.** Wear a face or dust mask if the sanding operation is dusty.

- **PROTECT YOUR HEARING.** Wear hearing protection during extended periods of operation.
- **DON'T ABUSE CORD.** Never carry tool by the cord or yank it to disconnect from receptacle. Keep cord away from heat, oil, and sharp edges.
- **DO NOT OVERREACH.** Keep proper footing and balance at all times.
- **MAINTAIN TOOLS WITH CARE.** Keep tools sharp and clean for best and safest performance. Follow instructions for lubricating and changing accessories.
- **NEVER LEAVE TOOL RUNNING UNATTENDED.** TURN POWER OFF. Disconnect all tools when not in use, before servicing, or when changing attachments, wheels, etc.
- **AVOID ACCIDENTAL STARTING.** Be sure switch is off when plugging in.
- **USE RECOMMENDED ACCESSORIES.** The use of improper accessories may cause risk of injury.
- **DO NOT USE incorrect size discs or belts.** NEVER touch belts or discs or other moving parts.
- **NEVER STAND ON TOOL.** Serious injury could occur if the tool is tipped or if the wheel is unintentionally contacted.
- **DIRECTION OF FEED.** Be aware of wheel rotation direction; never sand without the workrest being properly set. NEVER sand more than one workpiece at a time.



WARNING: Wheel coasts after turn off.

- **CHECK DAMAGED PARTS.** Before further use of the tool, a guard or other part that is damaged should be carefully checked to determine that it will operate properly and perform its intended function. Check for alignment of moving parts, binding of moving parts, breakage of parts, mounting and any other conditions that may affect its operation. A guard or other part that is damaged must be properly repaired or replaced by an authorised service centre to avoid risk of personal injury.
- **KEEP TOOL DRY, CLEAN, AND FREE FROM OIL AND GREASE.** Always use a clean cloth when cleaning. Never use brake fluids, gasoline, petroleum-based products, or any solvents to clean tool.
- **INSPECT TOOL CORDS AND EXTENSION CORDS PERIODICALLY** and, if damaged, have repaired by a qualified service technician. Stay constantly aware of cord location and keep it well away from the rotating wheel.
- **NEVER USE IN AN EXPLOSIVE ATMOSPHERE.** Normal sparking of the motor or sparking from grinding metal could ignite fumes.

RULES FOR SAFE OPERATION

- **USE OUTDOOR EXTENSION CORDS.** Use only extension cords with approved ground connection that are intended for use outdoors and so marked.
- **NEVER** reach to pick up a workpiece, a piece of scrap, or anything else that is in or near the sanding path of the wheel.
- **AVOID AWKWARD OPERATIONS AND HAND POSITIONS** where a sudden slip could cause your hand to move into the wheel. **ALWAYS** make sure you have good balance.
- **NEVER** stand or have any part of your body in line with the path of the belt or disc.
- **DO NOT USE TOOL IF SWITCH DOES NOT TURN IT ON AND OFF.** Have defective switches replaced by an authorised service centre.
- **DO NOT TURN THE MOTOR SWITCH ON AND OFF RAPIDLY.** This could cause the wheel to loosen and could create a hazard. Should this ever occur, stand clear and allow the wheel to come to a complete stop. Disconnect your belt & disc sander from the power supply and check tightness.
- **RISK OF INJURY DUE TO ACCIDENTAL STARTING.** Do not use in an area where children may be present.
- **NEVER START THE SANDER** when the wheel is in contact with the workpiece.
- **SECURE WORK.** Always hold workpiece firmly against the work rest.
- **FREQUENTLY** clean saw dust from beneath sander.
- **DO NOT OPERATE THIS TOOL WHILE UNDER THE INFLUENCE OF DRUGS, ALCOHOL, OR ANY MEDICATION.**
- **ALWAYS STAY ALERT.** Do not allow familiarity (gained from frequent use of your sander) to cause a careless injury. A fraction of a second is sufficient to inflict severe injury.
- **STAY ALERT AND EXERCISE CONTROL.** Watch what you are doing and use common sense. Do not operate tool when you are tired. Do not rush.
- **SAVE THESE INSTRUCTIONS.** Refer to them frequently and use them to instruct other users, If you loan someone this tool, loan them these instructions also.

WARNING:

When servicing use only identical Ryobi replacement parts. Use of any other parts may create a hazard or cause product damage.

IF ANY PART OF THIS SANDER IS MISSING or should break, bend, or fail in any way, or should any electrical component fail to perform properly, shut off the power switch, remove the machine plug from the power source and have damaged, missing, or failed parts replaced before resuming operation.

- **MAKE SURE THE SANDER IS SECURELY MOUNTED** as described in the operating instructions before connecting the tool to a power supply.
- **ADJUST** distance between wheel and work rest to maintain 1.6mm. or less separation .
- **ALWAYS EASE THE WORKPIECE AGAINST THE SANDING SURFACE** when starting to sand. Use light pressure when starting to sand.

WARNING:

Some dust created by power sanding, sawing, grinding, drilling, and other construction activities contains chemicals known to cause cancer, birth defects or other reproductive harm. Some examples of these chemicals are:

- . lead from lead-based paints.
- . crystalline silica from bricks and cement and other masonry products, and
- . arsenic and chromium from chemically-treated timber.

Your risk from these exposures varies, depending on how often you do this type of work. To reduce your exposure to these chemicals: work in a well ventilated area, and work with approved safety equipment, such as those dust masks that are specially designed to filter out microscopic particles.



RULES FOR SAFE OPERATION

The purpose of safety symbols is to attract your attention to possible dangers. The safety symbols, and the explanations with them, deserve your careful attention and understanding. The safety warnings do not by themselves eliminate any danger. The instructions or warnings they give are not substitutes for proper accident prevention measures.

SYMBOL MEANING



SAFETY ALERT SYMBOL:

Indicates danger, warning, or caution. May be used in conjunction with other symbols or pictographs.



DANGER: Failure to obey a safety warning will result in serious injury to yourself or others. Always follow the safety precautions to reduce the risk of fire, electric shock and personal injury.



WARNING: Failure to obey a safety warning may result in property damage or personal injury to yourself or to others. Always follow the safety precautions to reduce the risk of fire, electric shock and personal injury.



CAUTION: Failure to obey a safety warning may result in property damage or personal injury to yourself or to others. Always follow the safety precautions to reduce the risk of fire, electric shock and personal injury.

NOTE: Advises you of information or instructions vital to the operation or maintenance of the equipment.

IMPORTANT

Servicing requires extreme care and knowledge and should be performed only by a qualified service technician. For service we suggest you return the tool to your nearest RYOBI AUTHORISED SERVICE CENTRE for repair. When servicing, use only identical Ryobi replacement parts.



WARNING:

Do not attempt to operate this tool until you have read thoroughly and understand completely all instructions, safety rules, etc. contained in this manual. Failure to comply can result in accidents involving fire, electric shock, or serious personal injury. Save this operator's manual and review frequently for continuing safe operation and instructing others who may use this tool.



WARNING:

The operation of any sander can result in foreign objects being thrown into your eyes, which can result in severe eye damage. Before beginning power tool operation, always wear safety goggles or safety glasses with side shields and a full face shield when needed. We recommend Wide Vision Safety Mask for use over eyeglasses or standard safety glasses with side shields.

UNPACKING

- Carefully remove all parts from the shipping carton.
- Lift the bench belt & disc sander from the carton and place it on a level work surface.
- Do not discard the packing materials until you have carefully inspected the machine, identified all loose parts, and satisfactorily operated your belt and disc sander.
- Examine all parts to make sure no breakage or damage has occurred during shipping.
- If all parts have been included, proceed to assembly.
- If any parts are damaged or missing, do not attempt to

plug in this tool or turn it on until the damaged or missing parts are obtained and installed correctly.

- Contact your nearest Ryobi dealer for assistance if any parts are missing or damaged.



WARNING:

If any parts are missing do not operate this machine until the missing parts are replaced. Failure to do so could result in possible serious injury.

LOOSE PARTS LIST

The following items are included with your Belt & Disc Sander:

- Sanding Disc Table
- Sanding Belt Table
- Handles for Sanding Disc Table (2)
- Handle for Sanding Belt Table (2)
- Cover for Sanding Disc
- Rubber Feet (4)
- Mitre Gauge
- Sanding Disc
- Sanding Belt
- 3mm Hex Key

FEATURES

Before using the tool, familiarise yourself with all the operating features and safety requirements.

Use the tool and accessories only for the applications intended.

- | | |
|-------------------------------------|--------------------------------------|
| 1. Base | 10. Belt tracking adjustment knob |
| 2. Rubber Feet | 11. Belt cover |
| 3. Disc guard | 12. Belt guard |
| 4. Dust extraction for sanding disc | 13. Belt cover knob |
| 5. Sanding disc table | 14. Sanding belt table |
| 6. Mitre gauge | 15. Sanding belt table handle |
| 7. Sanding disc table handles | 16. Sanding belt platen |
| 8. On/off switch | 17. Dust extraction for sanding belt |
| 9. Motor | |

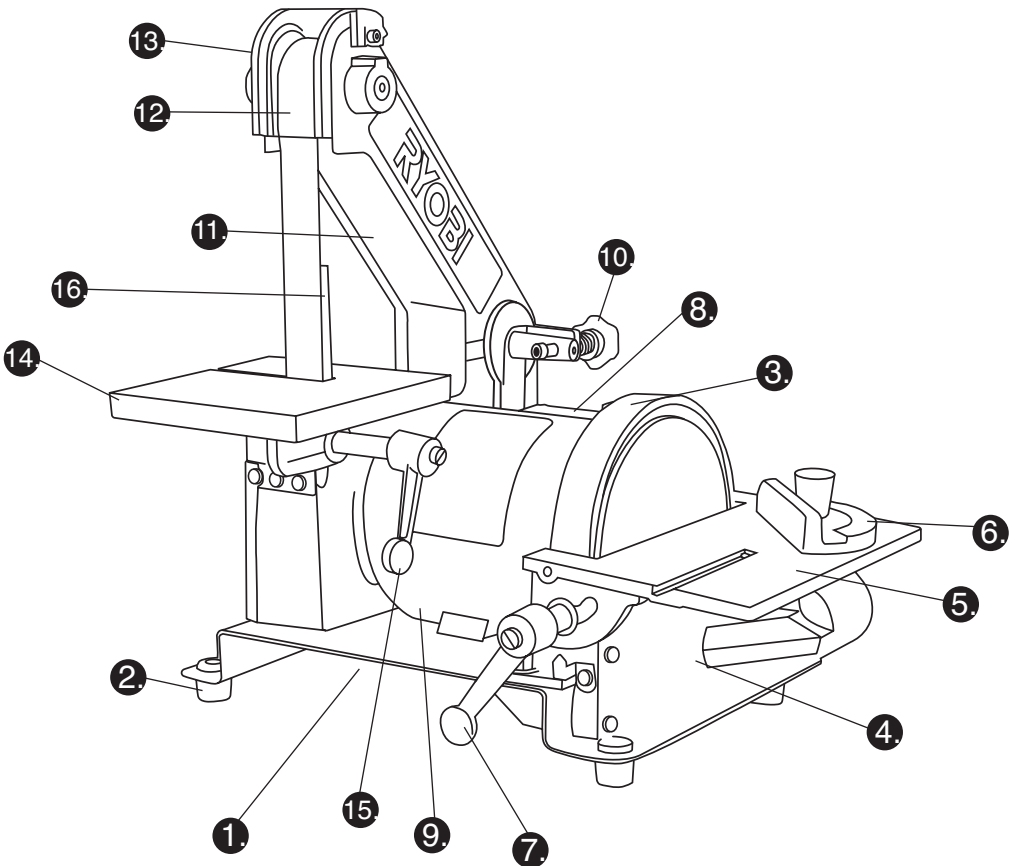

FEATURES – EMBS200

KNOW YOUR BELT AND DISC SANDER

Before attempting to use your new tool, familiarise yourself with all operating features and safety requirements. Carefully read this operator's manual before using your sander.

POWER SWITCH

Your EMBS200 Belt and Disc Sander features an easy access On/Off switch for convenience and safety.

MOTOR

Powered by a precision built electronic induction motor, your Belt and Disc Sander has sufficient power to handle tough sanding tasks.

SANDING DISC

Your EMBS200 uses a 125mm diameter hook and loop fitting sanding disc. These are available in various 'grits' or grades of coarseness from all good hardware stores.

SANDING BELT

Your EMBS200 uses a 762 x 25mm sanding belt. These are available from leading hardware stores.

SANDING TABLES

The sanding tables are independently adjustable to allow for a variety of sanding applications. Before sanding, ensure sanding tables are adjusted properly.

Adjust the sanding tables to maintain 1.6mm or less between the edge of the sanding table and the sanding surface.

SANDING BELT TRACKING

Allows for easier adjustment of the sanding belt when in use.

PLATEN

The EMBS200 is fitted with a platen to support the sanding belt during operation.

DUST PORTS

Dust Ports are located on the belt cover and sanding disc cover. They allow for a dust extraction unit to be connected for a cleaner and safer work environment.

Assembly

1. Attach the rubber feet onto the base by fitting them through each of the 4 holes in the base.
2. Attach the sanding disc onto the disc platen making sure that the edges of the disc fit perfectly onto the disc platen.

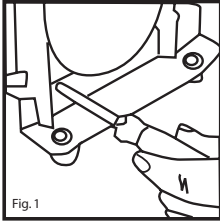

3. Loosen and remove the 4 screws and washers around the sanding disc. (Fig. 1)
4. Fit the sanding disc cover over the sanding disc.
5. Replace and tighten the 4 screws and washers to secure the disc cover in place.

6. Fit the sanding disc table onto the unit by sliding the 2 notches in the table through the 2 recesses in the disc guard housing. (Fig. 2)

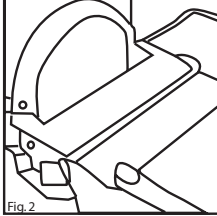

7. Secure the table by fitting the sanding disc table handle through the slot in the table bevel scale and the hole in the disc guard. Use the 2 handles with the shorter spindle. Ensure that the washer is fitted in between the handle and the bevel scale.

8. Tighten the handle by rotating it in a clockwise direction. The handle is spring loaded and can be repositioned by pulling on the handle and rotating to the required position.

9. Attach the handle on the opposite side of the sanding table by following steps 7 & 8.

10. Fit the mitre gauge by sliding it through the slot in the sanding disc table.
11. Fit the sanding belt table by sliding the slot in the table through the top part of the sanding belt above the backstop. (Fig. 3)

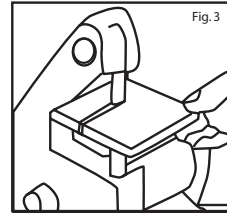

12. Lower the table down and secure it using the handle with the long spindle. Ensure that the washer is positioned in between the handle and the table.
13. Tighten the handle by rotating it in a clockwise direction. The handle is spring loaded and can be repositioned by pulling on the handle and rotating to the required position.

Mounting to a workbench

It is recommended that the belt and disc sander is secured to a work bench to gain maximum stability and prevent noise and vibration.

1. The belt and disc sander features 4 holes in the base to help secure it to a workbench.
2. Using the base of the belt & disc sander as a template mark the holes on the workbench through the holes in the casting.
3. Drill the holes through the workbench using a 12.7mm 1/2 inch drill bit.
4. Bolt the belt and disc sander to the workbench using bolts, washers and nuts.

Note. The fasteners are not supplied with the machine.

Adjusting the rear platen

The platen is designed to support the workpiece when using the belt sander. It should be adjusted so that it is almost touching the sanding belt.

1. To adjust the platen first tilt the sanding belt table to a 45° angle to gain better access to the 2 hex screws. (Fig. 4)
2. Loosen the 2 hex screws securing the platen using the 3mm hex key supplied.
3. Adjust the platen so that it is almost touching the sanding belt.
4. Tighten the 2 hex screws.

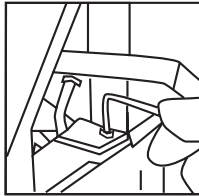

Fig. 4

Adjusting the sanding disc table angle

1. Loosen the 2 handles securing the sanding disc table.
2. Lower the table to the desired angle is reached, using the bevel scale as a guide.

3. Tighten the 2 handles to secure the table in position.

Adjusting the belt sander table

1. For most belt sanding operations the table should be set at a 90° angle to the sanding belt.
2. To check if the table is set at 90° place a square on the table and check if the table is at 90° to the belt.
3. If the table is not at 90° loosen the hex bolt at the bottom of the table and then using the hex key adjust the hex screw positioned at the top of the table. Adjust the hex screw until the table is at 90° to the belt. (Fig. 5 & 6)
4. Tighten the hex bolt to secure the hex screw in position.

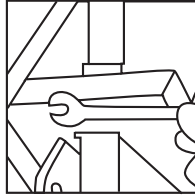

Fig. 5

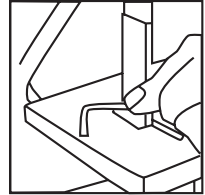

Fig. 6

5. To tilt the table and perform belt sanding on an angle loosen the handle securing the belt sander table.
6. Tilt the table to the desired angle and tighten the sanding belt table handle.

Note. Always adjust the table so that the gap between the belt and the table is no larger than 1-5mm.

Changing the sanding disc

1. Loosen and remove the 2 handles securing the sanding disc table.
2. Remove the sanding disc table.
3. Loosen and remove the 4 screws securing the disc cover.
4. Remove the disc cover.
5. Peel off the sanding disc from the disc platen.
6. Fit the new sanding disc over the disc platen.
7. Replace the disc cover.
8. Replace the sanding disc table and secure with the 2 handles.

Changing the sanding belt

1. Loosen and remove both screws securing the belt cover to the unit. One screw is located under the sanding table, the other on the angled section of the belt cover.
2. Remove the guard.
3. Loosen and remove the belt cover knob at the top of the unit. (Fig. 7)

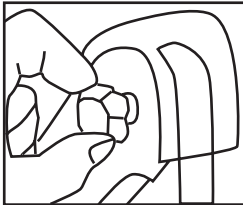

Fig. 7

5. Remove the belt cover.
6. Using the 3mm hex key loosen but do not remove the hex screw securing the belt guard.
7. Lift off the belt guard. (Fig. 8)

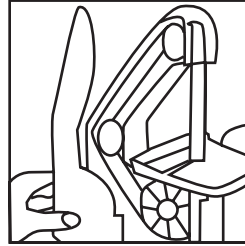

Fig. 8

8. Push the belt tracking adjustment knob towards the front of the unit to reduce the belt tension and whilst holding it in this position remove the belt from the 3 wheels.
9. Push the belt tracking adjustment knob towards the front of the unit to reduce the belt tension and whilst holding it in this fit the new belt over the 3 wheels.
10. Ensure the 2 locating lugs are positioned into the base of the unit when refitting the belt cover.
11. Replace the belt cover and replace the 2 Phillips head screws and belt cover knob to secure the cover in position.

Adjusting the belt tracking

The belt tracking adjustment knob helps to ensure that the belt is aligned on the wheels. (Fig 9)

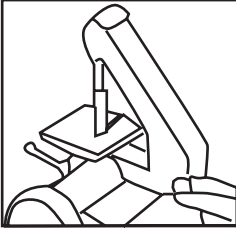

Fig. 9

1. To track the belt to the right rotate the knob in a clockwise direction.
2. To track the belt to the left rotate the knob in an anti-clockwise direction.
3. Rotate the belt with your fingers to ensure it is aligned properly on the wheels.

Dust extraction

Dust extraction chutes are located on the belt cover and the sanding disc cover. They allow a dust extraction unit to be connected for a cleaner and safer working environment.

Turning on and off

1. To start the machine push the switch to the ON (I) position. When turning the machine ON stand to either side of it and never in front of the sanding belt. Allow the machine to reach full speed before performing a sanding application. To stop the machine push the switch to the OFF (O) position.

Operation

Using the mitre gauge

1. The mitre gauge is used to help support the workpiece and can be adjusted when sanding an angle.
2. To adjust the mitre gauge loosen the knob at the top of the mitre gauge.
3. Rotate the mitre gauge until the desired angle is reached.
4. Tighten the mitre gauge knob to secure the angle.

Using the sanding disc

WARNING. To avoid trapping work or fingers in between the table and sanding disc the table should be repositioned on the table support to retain a maximum of 1.5mm distance between the sanding surface and the table.

1. Turn on the belt & disc sander.
2. Position the workpiece on the table and move it into the left hand side of the sanding disc so that it is sanded on the downstroke. (Fig10)

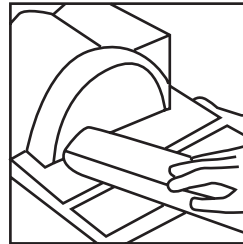

Fig. 10

3. The mitre gauge can be used to assist in keep the workpiece level and helps when sanding at specific angles.
4. Turn off the belt & disc sander on completion of the operation.

WARNING. Applying the workpiece on the right hand side of the disc can cause the workpiece to fly up and result in injury.

Using the sanding belt

1. Turn on the belt & disc sander.
2. Position the workpiece on the table and hold it firmly with both hands ensuring that you keep your fingers away from the sanding belt.
3. Keep the end butted against the backstop and move the workpiece evenly across the sanding belt.
4. Use extra caution when sanding very thin pieces.

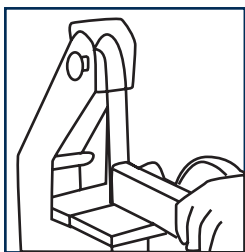

Maintenance

All the bearings are sealed ball bearings, lubricated for life, and require no maintenance.

Cleaning

1. Keep the tool's air vents unclogged and clean at all times.
2. Remove dust and dirt regularly. Cleaning is best done with a soft brush or a rag.
3. Re-lubricate all moving parts at regular intervals.
4. Never use caustic agents to clean plastic parts.

CAUTION. Do not use cleaning agents to clean the plastic parts of the tool. A mild detergent on a damp cloth is recommended.

General inspection

Regularly check that all the fixing screws are tight. They may vibrate loose over time.

Repairs

Only an authorised Ryobi service centre should replace the cordset or carry out other repairs. If the cordset is damaged or worn, have it repaired or replaced by it repaired or replaced by an authorised Ryobi service agent.

Trouble shooting

Warning!

Turn the on/off switch to the off position and unplug the tool from the power supply before performing trouble shooting procedures.

Trouble	Problem	Suggested remedy
Belt & disc sander will not start	Power cord not plugged in	Ensure that the cord is connected to the power supply
	Power fault, fuse or circuit breaker tripped	Check the power supply
	Cord damaged	Use authorised service centre to repair or replace
	Burned out switch	Use authorised service centre to repair or replace
	Faulty motor	Use authorised service centre to repair or replace the motor
Sanding disc or belt do not reach full speed	Extension cord too long or undersized	Use extension cord heavy enough to carry the current
	Tool is overheating	Turn off the tool and let it cool down to room temperature. Inspect and clean the ventilation slots
Sanding belt not running straight	Sanding belt not aligned	Use the belt tracking knob to align the sanding belt on the wheels
Vibration or abnormal noise	Loose parts	Check to see that all handles and screws are secure including the table locking handles, disc cover screws and belt cover screws.
	Moving parts excessively worn	Use authorised service centre to repair or replace

RYOBI TECHNOLOGIES AUSTRALIA PTY. LTD.

GUARANTEE



Subject to the guarantee condition below, this Ryobi tool (hereinafter called "the product") is guaranteed by Ryobi (hereinafter called "the Company") to be free from defects in material or workmanship for a period of 24 months from the date of original purchase covering both parts and labour. Under the terms of this guarantee, the repair or replacement of any part shall be the opinion of the Company or its authorised agent. Should service become necessary during the warranty period, the owner should contact the RYOBI HELPLINE 1300 361 505 or contact the retailer from whom the product was purchased.

In order to obtain guarantee service, the owner must present the sales docket and Guarantee Certificate to confirm date of purchase. This product is sold by the dealer or agent as principal and the dealer has no authority from the Company to give any additional guarantee on the Company's behalf except as herein contained or herein referred to.

Guarantee Conditions

This guarantee only applies provided that the Product has been used in accordance with the manufacturer's recommendations under normal use and reasonable care (in the opinion of the Company) and such

guarantee does not cover damage, malfunction or failure resulting from misuse, neglect, abuse, or used for a purpose for which it was not designed or is not suited and no repairs, alterations or modifications have been attempted by other than an Authorised Service Agent. This guarantee will not apply if the tool is damaged by accident or if repairs arise from normal wear and tear.

The Company accepts no additional liability pursuant to this guarantee for the costs of travelling or transportation of the Product or parts to and from the service dealer or agent - such costs are not included in this guarantee.

Certain legislation, including the Trade Practices Act, 1974 (as amended) and other state and territorial laws give rights to the buyer and impose liability on the seller in certain circumstances. Nothing herein shall have the effect of excluding, restricting or modifying any condition, guarantee, right or liability imposed, to the extent only that such exclusion, restriction or modification would render any term herein void.

RYOBI®

RYOBI TECHNOLOGIES AUSTRALIA PTY. LTD.

A.B.N. 98 002 277 509

SYDNEY: 359-361 Horsley Road, Milperra, N.S.W. 2214.

Contact during normal business hours.

Tel: (02) 9792 9800 - Fax: 1800 807 993 - www.ryobi.com.au

BRISBANE : All enquiries Tel : 1300 361 505
TOWNSVILLE: All enquiries Tel : 1300 361 505
MELBOURNE: 960 Stud Road, Rowville, Vic. 3178
Tel : (03) 9764 8656

HOBART: All enquiries Tel : 1300 361 505
ADELAIDE: All enquiries Tel : 1300 361 505
PERTH: 33-35 Sorbonne Cres. Canning Vale, W.A. 6155
Tel : (08) 9455 7775

RYOBI NEW ZEALAND PTY. LTD.

AUCKLAND: 27 Clemow Drive, Mt Wellington, N.Z.

Tel: (09) 573 0230 - Free Call: 0800 279 624 - Fax: (09) 573 0231 - www.ryobi.co.nz

Contact during normal business hours.

This Guarantee Form Should Be Retained By The Customer At All Times

For your record and to assist in establishing date of purchase (necessary for in-guarantee service) please keep your purchase docket and this form completed with the following particulars.

Address Of Dealer _____

Date _____ Model No _____ Serial No _____

Present This Form With Your Purchase Docket When Guarantee Service Is Required.