

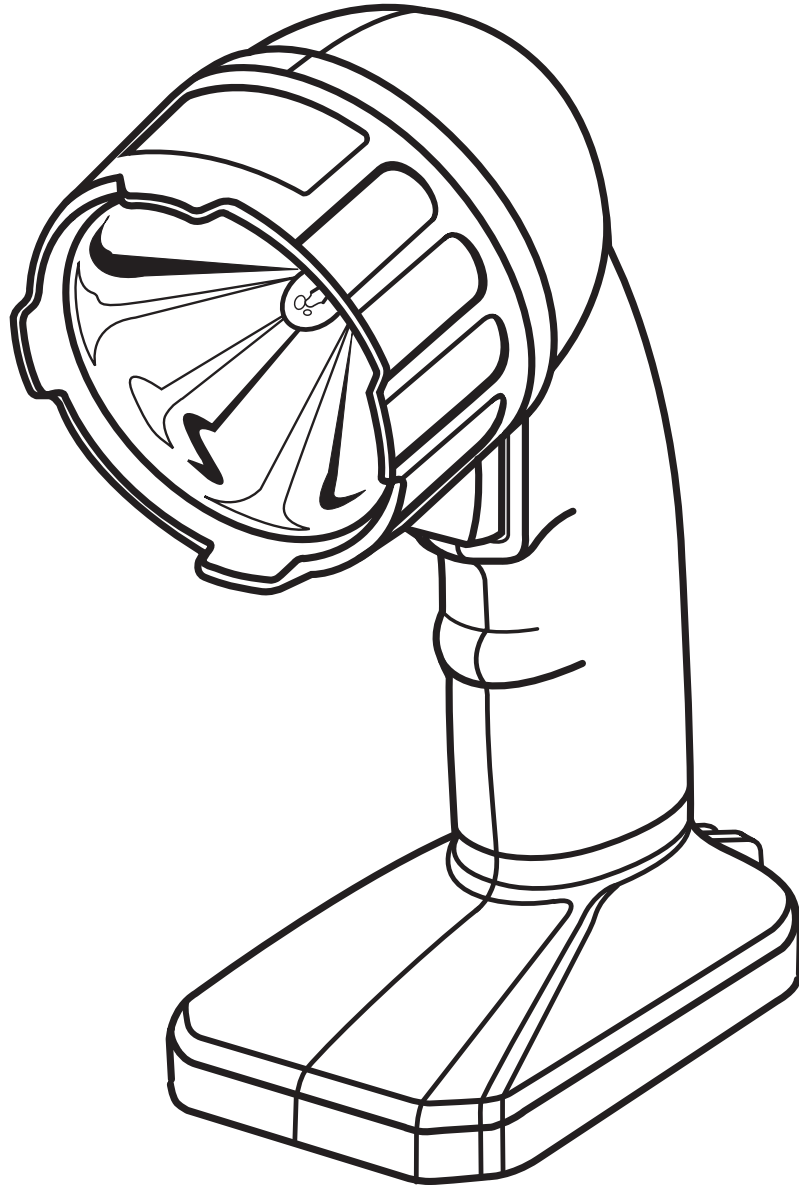

# OPERATOR'S MANUAL

## 18 VOLT CORDLESS FLASHLIGHT

### CFL180L



**BATTERIES  
AND CHARGERS  
SOLD SEPARATELY**

Your cordless flashlight has been engineered and manufactured to Ryobi's high standards for dependability, ease of operation and operator safety. When properly cared for, it will give you years of rugged, trouble-free performance.

**⚠ WARNING:** To reduce the risk of injury, the user must read and understand the operator's manual before using this product.

Thank you for buying a Ryobi product.

**SAVE THIS MANUAL FOR FUTURE REFERENCE**

# TABLE OF CONTENTS

■ Introduction.....	2
■ General Safety Rules .....	3
■ Specific Safety Rules.....	3-4
■ Safety Rules for Charger.....	4
■ Symbols .....	5-6
■ Features .....	7
■ Assembly .....	8
■ Operation .....	9-11
■ Maintenance .....	12-13
■ Parts Ordering/Service .....	14

## INTRODUCTION

This flashlight has many features for making its use more pleasant and enjoyable. Safety, performance and dependability have been given top priority in the design of this product making it easy to maintain and operate.

# GENERAL SAFETY RULES



## WARNING!

**READ AND UNDERSTAND ALL INSTRUCTIONS.** Failure to follow all instructions listed below, may result in electric shock, fire and/or serious personal injury.

## SAVE THESE INSTRUCTIONS

### WORK AREA

- **Keep your work area clean and well lit.** Cluttered benches and dark areas invite accidents.
- **Do not operate flashlight in explosive atmospheres, such as in the presence of flammable liquids, gases or dust.**

### ELECTRICAL SAFETY

- **A battery operated flashlight with integral batteries or a separate battery pack must be recharged only with the specified charger for the battery.** A charger that may be suitable for one type of battery may create a risk of fire when used with another battery.
- **Use battery operated flashlight only with specifically designated battery pack.** Use of any other batteries may create a risk of fire.

- **Use battery only with charger listed.**

MODEL	BATTERY PACK	CHARGER
CFL180L	ABP1801/1802/180311804	ACR1800

### FLASHLIGHT USE AND CARE

- **When battery pack is not in use, keep it away from other metal objects like: paper clips, coins, keys, nails, screws or other small metal objects that can make a connection from one terminal to another.** Shorting the battery terminals together may cause sparks, burns or a fire.

### SERVICE

- **Tool service must be performed only by qualified repair personnel.** Service or maintenance performed by unqualified personnel may result in a risk of injury.
- **When servicing a tool, use only identical replacement parts. Follow instructions in the Maintenance section of this manual.** Use of unauthorised parts or failure to follow Maintenance Instructions may create a risk of shock or injury.

# SPECIFIC SAFETY RULES

- **Know your flashlight. Read operator's manual carefully. Learn its applications and limitations, as well as the specific potential hazards related to this flashlight.** Following this rule will reduce the risk of electric shock, fire or serious injury.
- **Lens and bulb become hot during use:**
  - During or immediately after use, don't lay flashlight flat on lens surface or place lens area in contact with a plastic or fabric covered surface.
  - Handle flashlight with care around any flammable surface.
  - Let flashlight cool for several minutes after use before changing bulb.
  - Do not use or permit use of flashlight in bed or sleeping bags. This flashlight lens can melt fabric and a burn injury could result.
- **Use only the charger recommended for use with your flashlight.** Do not substitute any other charger. Use of another charger could cause batteries to explode causing possible serious injury.
- **Do not charge battery tool in a damp or wet location.** Following this rule will reduce the risk of electrical shock.
- **Your battery flashlight should be charged in a location where the temperature is more than 10°C but less than 38°C.**

- **Under extreme usage or temperature conditions, battery leakage may occur.** If liquid comes in contact with your skin, wash immediately with soap and water, then neutralize with lemon juice or vinegar. If liquid gets in your eyes, flush them with clean water for at least 10 minutes, then seek immediate medical attention.
- **Batteries vent hydrogen gas and can explode in the presence of a source of ignition, such as a pilot light.** To reduce the risk of serious personal injury, never use any cordless product in the presence of open flame. An exploded battery can propel debris and chemicals. If exposed, flush with water immediately.
- **Never use a battery pack that has been damaged or received a sharp blow.** A damaged battery pack is subject to explosion. Properly dispose of a damaged battery pack immediately. Failure to heed this warning can result in serious personal injury.
- **Use only recommended battery pack with your flashlight.** Any attempt to use another battery pack will cause damage to your flashlight and could possibly explode, cause a fire or personal injury.
- **Remove battery pack from flashlight before replacing bulb or performing any routine maintenance or cleaning.**
- **Do not disassemble your flashlight.**

## SPECIFIC SAFETY RULES

- **Do not permit children to use flashlight unsupervised.** It is not a toy. The temperature of the bulb will become hot after being on for only a short period of time. This hot temperature can cause burn injury if touched and can create sufficient heat to melt some fabrics.
- **Stay alert.** Watch what you are doing and use common sense. Do not rush.
- **If wrapped or in contact with fabrics, the flashlight lens can produce sufficient heat to melt some fabrics.** To avoid serious personal injury, never allow the flashlight lens to come in contact with anything.
- **Check damaged parts.** Before further use of this flashlight, a part that is damaged should be carefully checked to determine that it will operate properly and perform its intended function. Do not use flashlight if it does not function properly.

## SAFETY RULES FOR CHARGER



### WARNING!

**READ AND UNDERSTAND ALL INSTRUCTIONS.** Failure to follow all instructions listed below, may result in electric shock, fire and/or serious personal injury.

- Before using battery charger, read all instructions and cautionary markings in this manual, on battery charger, battery and product using battery to prevent misuse of the products and possible injury or damage.













### CAUTION:

To reduce the risk of electric shock or damage to the charger and battery, charge only nickel-cadmium rechargeable batteries as specifically designated on your charger. Other types of batteries may burst, causing personal injury or damage.

- **Do not use charger outdoors or expose to wet or damp conditions.** Water entering charger will increase the risk of electric shock.
- **Use of an attachment not recommended or sold by the battery charger manufacturer may result in a risk of fire, electric shock or injury to persons.** Following this rule will reduce the risk of electric shock, fire or serious personal injury.
- **Do not abuse cord or charger.** Never use the cord to carry the charger. Do not pull the charger cord rather than the plug when disconnecting from receptacle. Damage to the cord or charger could occur and create an electric shock hazard. Replace damaged cords immediately.
- **Make sure cord is located so that it will not be stepped on, tripped over, come in contact with sharp edges or moving parts or otherwise subjected to damage or stress.** This will reduce the risk of accidental falls, which could cause injury and damage to the cord, which could result in electric shock.
- **Keep cord and charger away from heat to prevent damage to housing or internal parts.**
- **Do not let gasoline, oils, petroleum-based products etc. come in contact with plastic parts.** They contain chemicals that can damage, weaken or destroy plastic.
- **An extension cord should not be used unless absolutely necessary.** Use of improper extension cord could result in a risk of fire and electric shock. If extension cord must be used, make sure:
  - a. That pins on plug of extension cord are the same number, size and shape as those of plug on charger.
  - b. That extension cord is properly wired and in good electrical condition;
  - c. That wire size is large enough for AC ampere rating of charger.
- **Do not operate charger with a damaged cord or plug,** which could cause shorting and electric shock. If damaged, have the charger replaced by an authorised service agent.
- **Do not operate charger if it has received a sharp blow, been dropped or otherwise damaged in any way.** Take it to an authorised service agent for electrical check to determine if the charger is in good working order.
- **Do not disassemble charger.** Take it to an authorised service agent when service or repair is required. Incorrect reassembly may result in a risk of electric shock or fire.
- **Unplug charger from outlet before attempting any maintenance or cleaning to reduce the risk of electric shock.**
- **Disconnect charger from the power supply when not in use.** This will reduce the risk of electric shock or damage to the charger if metal items should fall into the opening. It also will help prevent damage to the charger during a power surge.
- **Risk of electric shock.** Do not touch uninsulated portion of output connector or uninsulated battery terminal.
- **Save these instructions.** Refer to them frequently and use them to instruct others who may use this flashlight. If you loan someone this flashlight, loan them these instructions also to prevent misuse of the product and possible injury.
- **The appliance is not intended for use by young children or infirm persons without supervision.**
- **Young children should be supervised to ensure that they do not play with the appliance/charger.**



# SYMBOLS

Some of the following symbols may be used on this flashlight. Please study them and learn their meaning. Proper interpretation of these symbols will allow you to operate the flashlight better and safer.

SYMBOL	NAME	DESIGNATION/EXPLANATION
V	Volts	Voltage
A	Amperes	Current
Hz	Hertz	Frequency (cycles per second)
W	Watt	Power
min	Minutes	Time
~	Alternating Current	Type of current
≡	Direct Current	Type or a characteristic of current
$n_0$	No Load Speed	Rotational speed, at no load
	Class II Construction	Double-insulated construction
.../min	Per Minute	Revolutions, strokes, surface speed, orbits etc., per minute
	Wet Conditions Alert	Do not expose to rain or use in damp locations.
	Read The Operator's Manual	To reduce the risk of injury, user must read and understand operator's manual before using this product.
	Eye Protection	Always wear safety goggles or safety glasses with side shields and a full face shield when operating this product.
	Safety Alert	Precautions that involve your safety.
	No Hands Symbol	Failure to keep your hands away from the blade will result in serious personal injury.
	No Hands Symbol	Failure to keep your hands away from the blade will result in serious personal injury.
	No Hands Symbol	Failure to keep your hands away from the blade will result in serious personal injury.
	No Hands Symbol	Failure to keep your hands away from the blade will result in serious personal injury.
	Hot Surface	To reduce the risk of injury or damage, avoid contact with any hot surface.

# SYMBOLS

The following signal words and meanings are intended to explain the levels of risk associated with this product.

SYMBOL	SIGNAL	MEANING
	<b>DANGER:</b>	Indicates an imminently hazardous situation, which, if not avoided, will result in death or serious injury.
	<b>WARNING:</b>	Indicates a potentially hazardous situation, which, if not avoided, could result in death or serious injury.
	<b>CAUTION:</b>	Indicates a potentially hazardous situation, which, if not avoided, may result in minor or moderate injury.
	<b>CAUTION:</b>	(Without Safety Alert Symbol) Indicates a situation that may result in property damage.

## SERVICE

Servicing requires extreme care and knowledge and should be performed only by a qualified service technician. For service we suggest you return the product to your nearest **AUTHORISED SERVICE CENTRE** for repair. When servicing, use only identical replacement parts.



## WARNING:

To avoid serious personal injury, do not attempt to use this product until you read thoroughly and understand completely the operator's manual. Save this operator's manual and review frequently for continuing safe operation and instructing others who may use this product.

# SAVE THESE INSTRUCTIONS

# FEATURES

## PRODUCT SPECIFICATIONS

Battery .....	18 Volt DC
Charger Input .....	240 V, 50 Hz, AC only
Charge Rate .....	1 hour

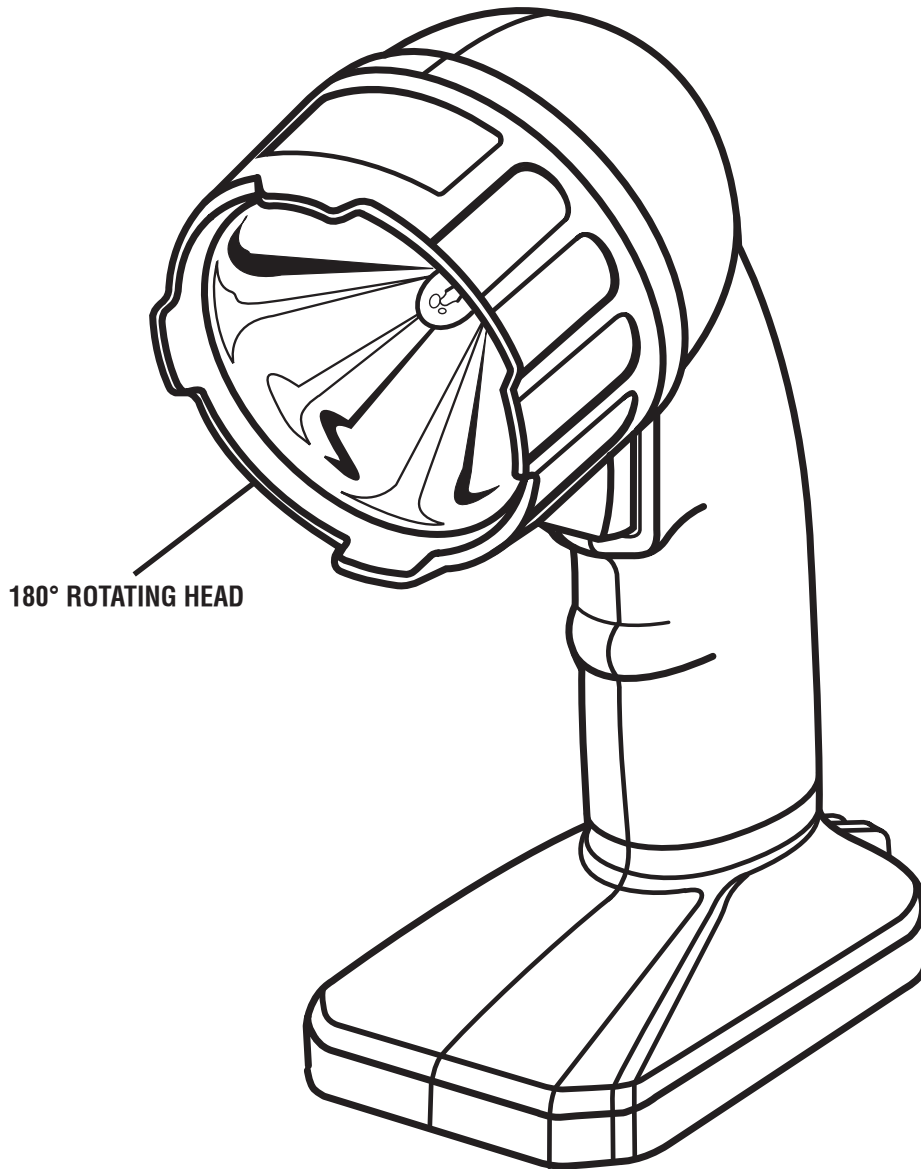

Fig. 1

### KNOW YOUR FLASHLIGHT

See Figure 1.

Before attempting to use this product, familiarize yourself with all operating features and safety rules.

### 180° ROTATING HEAD

Pivoting head rotates 180° allowing light to be projected in any direction.

# ASSEMBLY

## UNPACKING

This product has been shipped completely assembled.

- Carefully remove the flashlight and any accessories from the box. Make sure that all items listed in the packing list are included.
- Inspect the flashlight carefully to make sure no breakage or damage occurred during shipping.
- Do not discard the packing material until you have carefully inspected and satisfactorily operated the flashlight.
- If any parts are damaged or missing, please call 1300 361 505 for assistance.

## PACKING LIST

Flashlight

Plug-in Lanyard

Operator's Manual



### WARNING:

If any parts are missing do not operate this flashlight until the missing parts are replaced. Failure to do so could result in possible serious personal injury.



### WARNING:

Do not attempt to modify this flashlight or create accessories not recommended for use with this flashlight. Any such alteration or modification is misuse and could result in a hazardous condition leading to possible serious personal injury.



### WARNING:

Always remove the battery pack from the flashlight when assembling parts or changing light bulb. Failure to do so could result in possible serious personal injury.

# OPERATION

## **WARNING:**

Do not allow familiarity with flashlights to make you careless. Remember that a careless fraction of a second is sufficient to inflict serious injury.

## **WARNING:**

Do not use any attachments or accessories not recommended by the manufacturer of this flashlight. The use of attachments or accessories not recommended can result in serious personal injury.

## **CAUTION:**

To prevent damage to the battery pack, remove the battery pack from the charger immediately if no LED comes on. Return the battery pack and charger to your nearest service centre for checking or replacing. Also, if you are removing the battery pack from the charger and no LEDs are on, return both the battery pack and the charger to your nearest service centre. Do not insert another battery pack into the charger. A damaged charger may damage a battery pack.

## **CHARGING THE FLASHLIGHT**

If the flashlight did not come in a cordless kit with other cordless products, a battery pack and charger were not included.

## **LED FUNCTIONS OF CHARGER**

### **LED WILL BE ON TO INDICATE STATUS OF CHARGER AND BATTERY PACK:**

See Figure 2.

- Red LED on = Fast charging mode.
- Green LED on = Fully charged and in maintenance charge mode.
- Green LED on = When battery pack is inserted into charger, indicates hot battery pack or that battery pack is out of normal temperature range.
- Yellow and Green LEDs on = Deeply discharged or defective battery pack.
- No LED on = Defective charger or battery pack.

## **CHARGING THE BATTERY PACK**

Battery packs for this flashlight are shipped in a low charge condition to prevent possible problems. Therefore, you should charge it until the green LED on the front of the charger comes on.

**NOTE:** Batteries will not reach full charge the first time they are charged. Allow several cycles (operation followed by recharging) for them to become fully charged.

## **CHARGING A COOL BATTERY PACK**

If battery pack is within normal temperature range, the red LED on charger will come on.

**NOTE:** If the charger does not charge the battery pack under normal circumstances, return both the battery pack and charger to your nearest Ryobi Authorised Service Centre for electrical check.

- Charge the battery pack only with a recommended charger.
- Make sure the power supply is normal household voltage, **240 volts, 50 Hz, AC only**.
- Connect the charger to the power supply.
- Place the battery pack in the charger aligning raised rib on the battery pack with the groove in the charger. See *Figure 3*.
- Press down on the battery pack to be sure contacts on the battery pack engage properly with contacts in the charger.
- Normally the red LED on charger will come on. This indicates the charger is in fast charging mode.
- Red LED should remain on for approximately 1 hour then the green LED will come on. Green LED on indicates battery pack is fully charged and charger is in maintenance charge mode.

**NOTE:** The green LED will remain on until the battery pack is removed from the charger or charger is disconnected from the power supply.

- If both yellow and green LEDs come on, this indicates a deeply discharged or defective battery pack. Allow the battery pack to remain in the charger for 15 to 30 minutes. When the battery pack reaches normal voltage range, the red LED should come on. If the red LED does not come on after 30 minutes, this may indicate a defective battery pack and should be replaced.

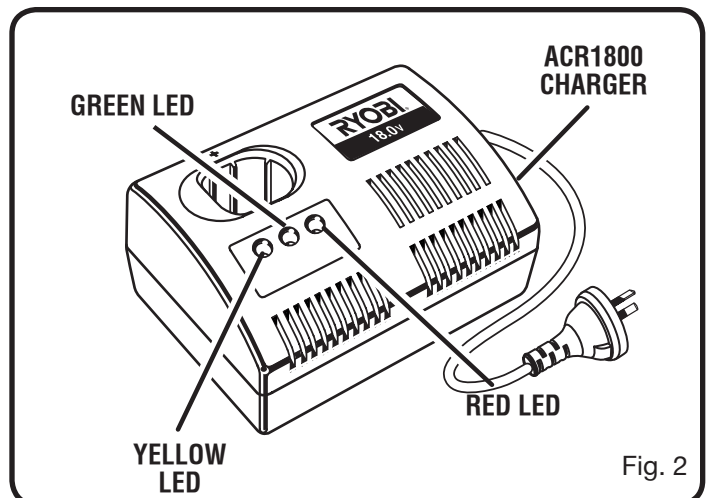

Fig. 2

# OPERATION

- After normal usage, a minimum of 1 hour of charging time is required to fully recharge battery pack.
- The battery pack will become slightly warm to touch while charging. This is normal and does not indicate a problem.
- Do not place the charger and battery pack in an area of extreme heat or cold. They will work best at normal room temperature.  
**NOTE:** The charger and battery pack should be placed in a location where the temperature is more than 10°C but less than 38°C.
- When batteries become fully charged, unplug the charger from power supply and remove the battery pack.

## CHARGING A HOT BATTERY PACK

When using the flashlight continuously, the batteries in the battery pack will become hot. You should let a hot battery pack cool down for approximately 30 minutes before attempting to recharge. When the battery pack becomes discharged and is hot, this will cause the green LED to come on instead of the red LED. After 30 minutes, reinsert the battery pack in the charger. If the green LED continues to remain on, return battery pack to your nearest Ryobi Authorised Service Centre for checking or replacing.

**NOTE:** This situation only occurs when continuous use of the flashlight causes the batteries to become hot. It does not occur under normal circumstances. Refer to “**CHARGING A COOL BATTERY PACK**” for normal recharging of batteries. If the charger does not charge your battery pack under normal circumstances, return both the battery pack and charger to your nearest Ryobi Authorised Service Centre for electrical check.

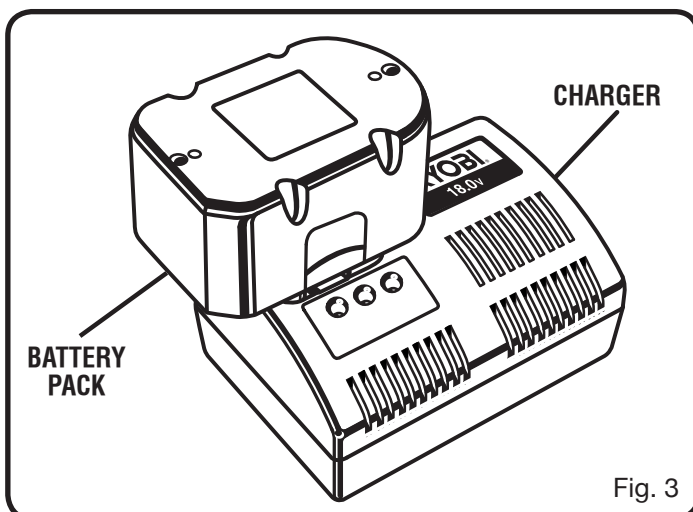

## TO INSTALL BATTERY PACK

See Figure 4.

- Begin with a fully charged battery pack.
- Orient battery pack so that raised rib on battery pack aligns with groove inside flashlight. Battery pack is designed to fit only one way in flashlight handle.
- Insert battery pack, making sure latches on each side of battery pack snap in place and battery pack is secure in flashlight before use.

### CAUTION:

When placing battery pack in the flashlight, be sure raised rib on battery pack aligns with groove inside flashlight and latches snap into place properly. Improper installation of the battery pack can cause damage to internal components.

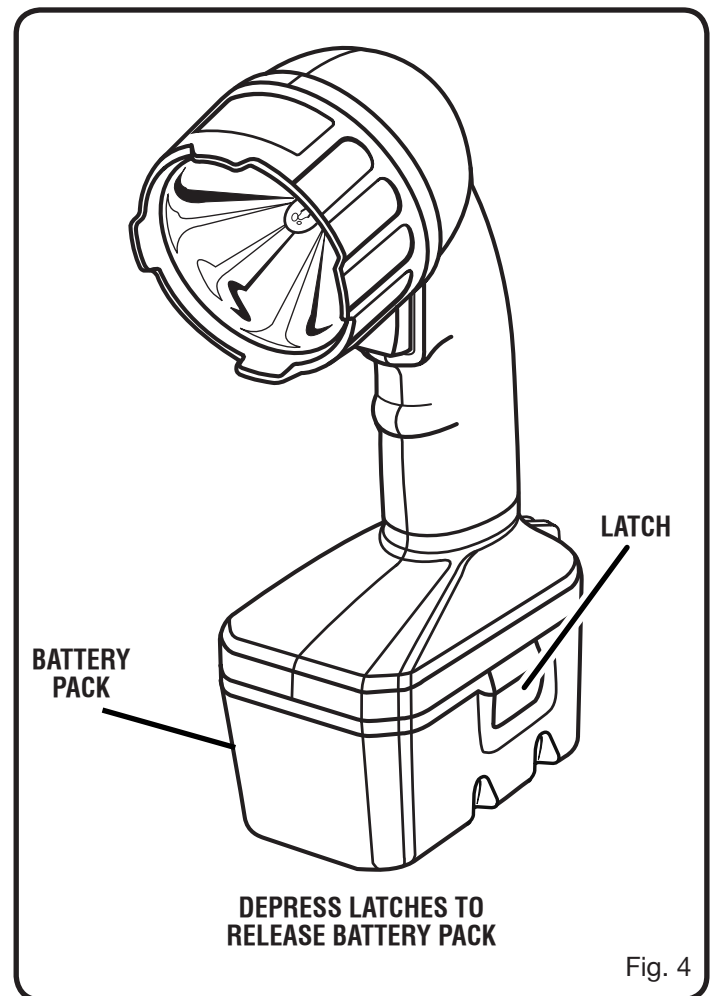

# OPERATION

## TO REMOVE BATTERY PACK

See Figure 4.

- To remove battery pack, locate latches on end of battery pack and depress to release battery pack from the flashlight.



### CAUTION:

Battery tools are always in operating condition. Use caution when carrying to prevent depressing the switch trigger when light is not needed.

## SWITCH

See Figure 5.

To turn the flashlight ON and OFF, depress the switch.

## 180° ROTATING HEAD

See Figure 5.

Rotate the head of flashlight to change the direction of light beam.

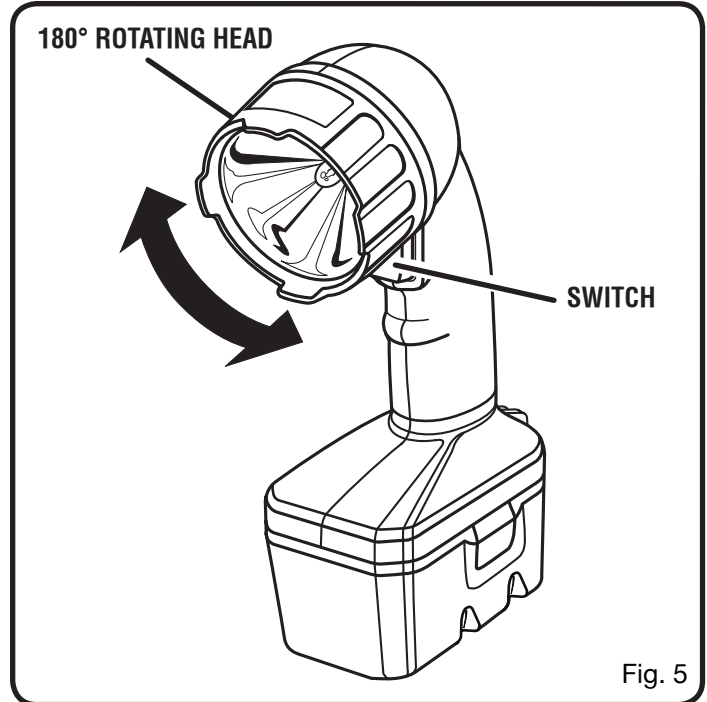

Fig. 5

# MAINTENANCE

## **⚠ WARNING:**

When servicing, use only identical Ryobi replacement parts. Use of any other parts may create a hazard or cause product damage.

## **⚠ WARNING:**

Always wear safety goggles or safety glasses with side shields when using compressed air to clean flashlights. If operation is dusty, also wear a dust mask.

## **⚠ WARNING:**

To avoid serious personal injury, always remove the battery pack from the flashlight when cleaning or performing any maintenance.

## GENERAL MAINTENANCE

Avoid using solvents when cleaning plastic parts. Most plastics are susceptible to damage from various types of commercial solvents and may be damaged by their use. Use clean cloths to remove dirt, dust, oil, grease etc.

## **⚠ WARNING:**

Do not at any time let brake fluids, gasoline, petroleum-based products, penetrating oils etc., come in contact with plastic parts. Chemicals can damage, weaken or destroy plastic which may result in serious personal injury.

Only the parts shown on the parts list are intended to be repaired or replaced by the customer. All other parts should be replaced at a Ryobi Authorised Service Centre.

## BULB REPLACEMENT

See Figure 6.

When purchasing replacement bulb, request recommended part number 780175002.

### TO REPLACE BULB:

- Allow bulb to cool.
- Remove battery pack by depressing side latches to release from flashlight.
- Remove lens cover by turning in a counterclockwise direction.
- Remove old bulb from spring by pulling out.
- Insert new bulb in spring and push in slightly to seat.
- Replace lens cover.
- Replace battery pack.

**NOTE:** For your convenience, the flashlight has a spare bulb storage area located behind the lens cover.

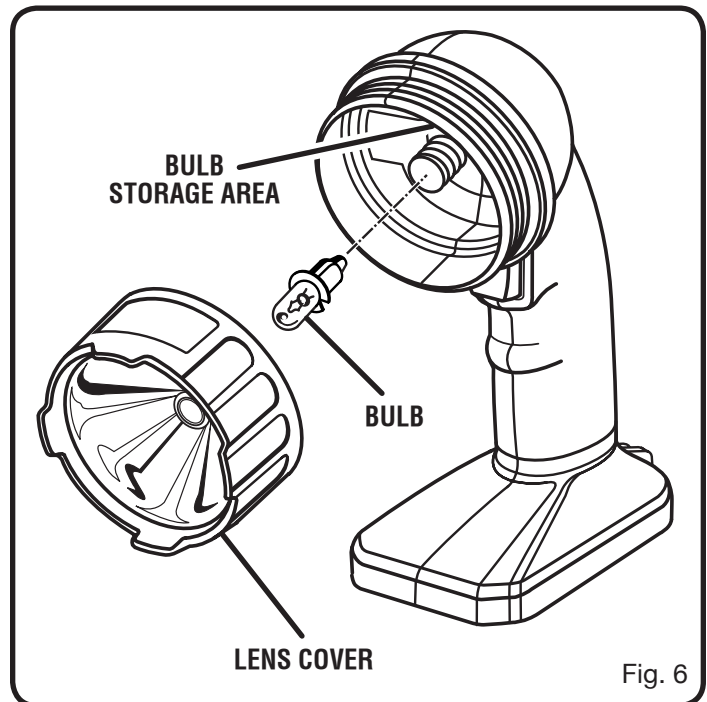

Fig. 6

# MAINTENANCE

## BATTERIES

The battery pack for this flashlight is equipped with nickel-cadmium rechargeable batteries. Length of service from each charging will depend on the type of work you are doing.

The batteries for this flashlight have been designed to provide maximum trouble-free life. However, like all batteries, they will eventually wear out. **Do not** disassemble battery pack and attempt to replace the batteries. Handling of these batteries, especially when wearing rings and jewelry, could result in a serious burn.

To obtain the longest possible battery life, we suggest the following:

- Remove the battery pack from the charger once it is fully charged and ready for use.
- Store battery pack removed from the tool.

For battery storage longer than 30 days:

- Store the battery pack where the temperature is below 27°C.
- Store battery packs in a “discharged” condition.



### WARNING:

Upon removal, cover the battery pack's terminals with heavy-duty adhesive tape. Do not attempt to destroy or disassemble battery pack or remove any of its components. Nickel-cadmium batteries must be recycled or disposed of properly. Also, never touch both terminals with metal objects and/or body parts as short circuit may result. Keep away from children. Failure to comply with these warnings could result in fire and/or serious injury.

**RYOBI TECHNOLOGIES AUSTRALIA PTY. LTD.**

# **GUARANTEE**



Subject to the guarantee condition below, this Ryobi tool (hereinafter called "the product") is guaranteed by Ryobi (hereinafter called "the Company") to be free from defects in material or workmanship for a period of 24 months from the date of original purchase covering both parts and labour. Under the terms of this guarantee, the repair or replacement of any part shall be the opinion of the Company or its authorised agent. Should service become necessary during the warranty period, the owner should contact the RYOBI HELPLINE 1300 361 505 or contact the retailer from whom the product was purchased.

In order to obtain guarantee service, the owner must present the sales docket and Guarantee Certificate to confirm date of purchase. This product is sold by the dealer or agent as principal and the dealer has no authority from the Company to give any additional guarantee on the Company's behalf except as herein contained or herein referred to.

#### **Guarantee Conditions**

This guarantee only applies provided that the Product has been used in accordance with the manufacturer's recommendations under normal use and reasonable care (in the opinion of the Company) and such

guarantee does not cover damage, malfunction or failure resulting from misuse, neglect, abuse, or used for a purpose for which it was not designed or is not suited and no repairs, alterations or modifications have been attempted by other than an Authorised Service Agent. This guarantee will not apply if the tool is damaged by accident or if repairs arise from normal wear and tear.

The Company accepts no additional liability pursuant to this guarantee for the costs of travelling or transportation of the Product or parts to and from the service dealer or agent - such costs are not included in this guarantee.

Certain legislation, including the Trade Practices Act, 1974 (as amended) and other state and territorial laws give rights to the buyer and impose liability on the seller in certain circumstances. Nothing herein shall have the effect of excluding, restricting or modifying any condition, guarantee, right or liability imposed, to the extent only that such exclusion, restriction or modification would render any term herein void.

# **RYOBI**

#### **RYOBI TECHNOLOGIES AUSTRALIA PTY. LTD.**

A.B.N. 98 002 277 509

SYDNEY: 359-361 Horsley Road, Milperra, N.S.W. 2214.

Contact during normal business hours.

Tel: (02) 9792 9800 - Fax: 1800 807 993 - [www.ryobi.com.au](http://www.ryobi.com.au)

**BRISBANE :** All enquiries Tel : 1300 361 505

**TOWNSVILLE:** All enquiries Tel : 1300 361 505

**MELBOURNE:** 960 Stud Road, Rowville, Vic. 3178

Tel : (03) 9764 8656

**HOBART:** All enquiries Tel : 1300 361 505

**ADELAIDE:** All enquiries Tel : 1300 361 505

**PERTH:** 33-35 Sorbonne Cres. Canning Vale, W.A. 6155

Tel : (08) 9455 7775

#### **RYOBI NEW ZEALAND PTY. LTD.**

**AUCKLAND:** 27 Clemow Drive, Mt Wellington, N.Z.

Tel: (09) 573 0230 - Free Call: 0800 279 624 - Fax: (09) 573 0231 - [www.ryobi.co.nz](http://www.ryobi.co.nz)

Contact during normal business hours.

### **This Guarantee Form Should Be Retained By The Customer At All Times**

For your record and to assist in establishing date of purchase (necessary for in-guarantee service) please keep your purchase docket and this form completed with the following particulars.

Address Of Dealer \_\_\_\_\_

Date \_\_\_\_\_ Model No \_\_\_\_\_ Serial No \_\_\_\_\_

Present This Form With Your Purchase Docket When Guarantee Service Is Required.