

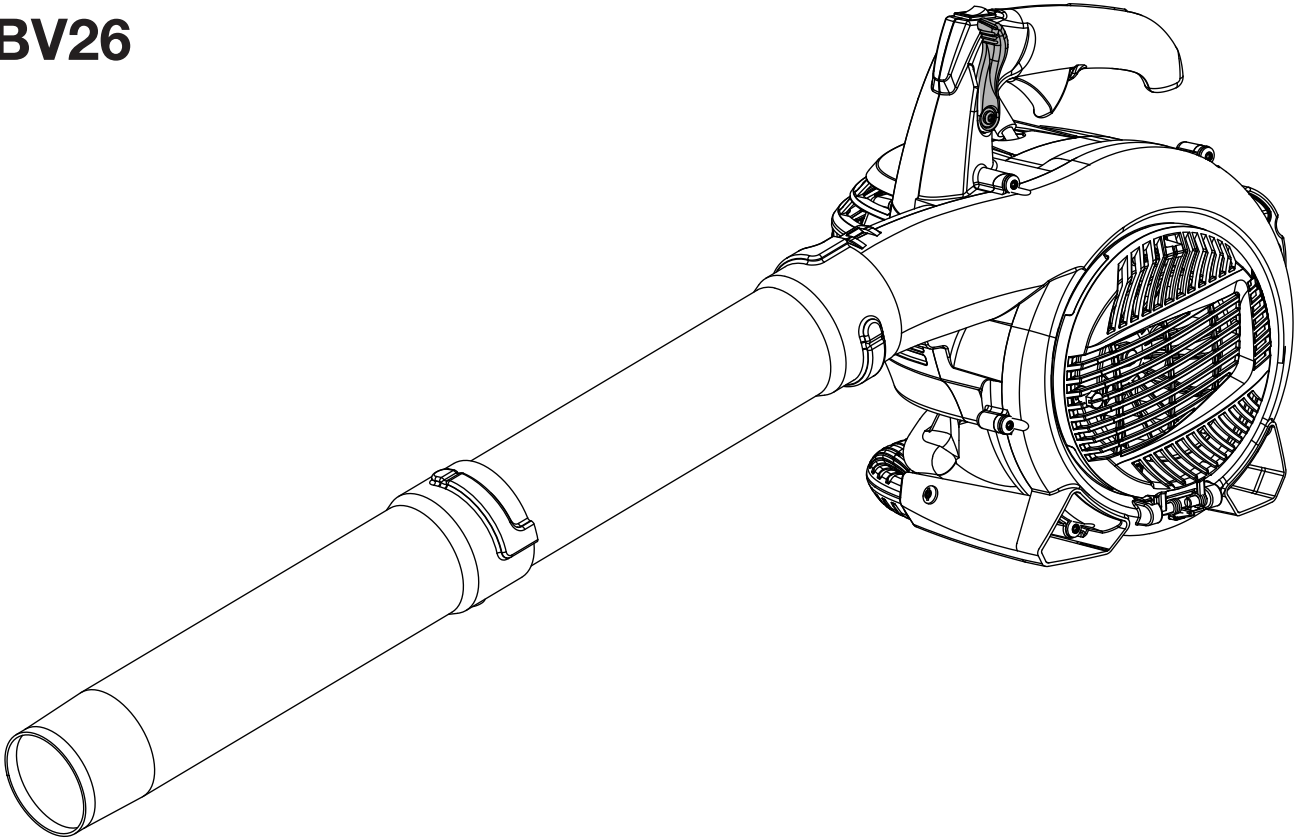

OPERATOR'S MANUAL

BLOWER/VACUUM

RBV26



N197

Your blower/vacuum has been engineered and manufactured to our high standard for dependability, ease of operation, and operator safety. When properly cared for, it will give you years of rugged, trouble-free performance.

⚠ WARNING: To reduce the risk of injury, the user must read and understand the operator's manual before using this product. If you do not understand the warnings and instructions in the operator's manual, do not use this product.

SAVE THIS MANUAL FOR FUTURE REFERENCE

INTRODUCTION

This product has many features for making its use more pleasant and enjoyable. Safety, performance, and dependability have been given top priority in the design of this product making it easy to maintain and operate.

GENERAL SAFETY RULES

WARNING:

Read and understand all instructions. Failure to follow all instructions listed below may result in electric shock, fire and/or carbon monoxide poisoning which will can cause death or serious personal injury.

- Do not allow children or untrained individuals to use this unit.
- Never start or run the engine inside a closed area; breathing exhaust fumes can kill.
- Always wear eye protection with side shields marked to comply with standards, along with hearing protection. Failure to do so could result in objects being thrown into your eyes and other possible serious injuries.
- Keep all bystanders, children, and pets at least 15m away.
- Wear heavy long pants, long sleeves, boots, and gloves. Do not wear any loose-fitting clothing, short pants, sandals, loose fitting jewelry of any kind, or go barefoot.
- To reduce the risk of injury associated with objects being drawn into rotating parts, do not wear loose clothing, scarves, neck chains, and the like. Secure long hair so it is above shoulder level to prevent entanglement in any rotating parts.
- Do not operate this unit when you are tired, ill, or under the influence of alcohol, drugs, or medication.
- Do not operate in poor lighting.
- Keep all parts of your body away from any moving parts and all hot surfaces of the unit.
- Wear a face filter mask in dusty conditions to reduce the risk of injury associated with the inhalation of dust.
- Check the work area before each use. Remove all objects such as rocks, broken glass, nails, wire, or string which can be thrown or become entangled in the machine.
- Keep firm footing and balance. Do not overreach. Overreaching can result in loss of balance or exposure to hot surfaces.
- Never operate the unit without a spark arrestor screen; this screen is located inside the muffler.
- Before storing the unit, allow the engine to cool.
- Use only Ryobi replacement parts and accessories. Failure to do so may cause poor performance or possible injury.
- Maintain the unit per maintenance instructions in this operator's manual.
- Inspect the unit before each use for loose fasteners, fuel leaks, etc. Replace damaged parts.
- Before cleaning, repairing, or inspecting, shut off the engine and make certain all moving parts have stopped. Disconnect the spark plug wire, and keep the wire away from the plug to prevent accidental starting.
- Service on the blower/vacuum must be performed by qualified repair personnel only. Service or maintenance performed by unqualified personnel could result in injury to the user or damage to the product.
- Use only identical replacement parts when servicing the blower/vacuum. Use of unauthorized parts may create a risk of serious injury to the user, or damage to the product.
- Do not use on a ladder, rooftop, tree, or other unstable support. Stable footing on a solid surface enables better control of the blower/vacuum in unexpected situations.

SPECIFIC SAFETY RULES



- Always hold the blower/vacuum in your right hand during blower operation. Refer to the **OPERATION** instructions later in this manual for proper position during vacuum operation and additional information.
- To reduce the risk of hearing loss associated with sound level(s), hearing protection is required.
- To reduce the risk of injury associated with contacting rotating parts, stop the engine before installing or removing attachments. Do not operate without guard(s) in place. Always disconnect the spark plug before performing maintenance or accessing any movable parts.
- Do not point the blower nozzle in the direction of people or pets.
- Never run the unit without the blower tubes installed.
- Never place objects inside the blower tubes.
- Use only as directed in this operator's manual.
- Do not operate vacuum without vacuum bag installed; flying debris could cause serious injury. Always close vacuum bag completely before operating.
- Rotating impeller blades can cause severe injury. Stop the engine and ensure impeller blades have stopped rotating before opening the vacuum door or installing/changing tubes. Do not put hands or any other object into the vacuum tubes while they are installed on the unit.
- Never run the unit without the proper equipment attached. When used as a blower, always install the blower tubes. When used as a vacuum, always install the vacuum tubes and vacuum bag. Make sure the vacuum bag is completely zipped when the unit is running to avoid flying debris.
- Avoid situations that could catch the vacuum bag on fire. Do not operate near an open flame. Do not vacuum warm ash from fireplaces, barbecue pits, brush piles, etc. Do not vacuum discarded cigars or cigarettes unless the cinders are completely cool.

FUELING









- Fuel is highly flammable. Take precautions when using to reduce the chance of serious personal injury.
- Store fuel in a cool, well-ventilated area, safely away from spark and/or flame-producing equipment.
- Store fuel in containers specifically designed for this purpose.
- Only refuel outdoors and do not smoke while refueling.
- Add fuel before starting the engine. Never remove the cap of the fuel tank or add fuel while the engine is running or when the engine is hot.
- Do not smoke while handling fuel.
- Mix and store fuel in a container approved for gasoline.
- Mix fuel outdoors where there are no sparks or flames.
- Loosen fuel cap slowly to release pressure and to keep fuel from escaping around the cap.
- Tighten the fuel cap securely after refueling.
- Wipe spilled fuel from the unit. Move 10m away from refueling site before starting engine.
- Never attempt to burn off spilled fuel under any circumstances.
- To reduce the risk of fire and burn injury, handle fuel with care. It is highly flammable.
- If fuel is spilled, do not attempt to start the engine but move the machine away from the area of spillage and avoid creating any source of ignition until fuel vapors have dissipated.
- Replace all fuel tank and container caps securely.
- Empty fuel tank into a container approved for gasoline and restrain the unit from moving before transporting in a vehicle.
- When draining the fuel tank, use an approved fuel storage container in a well-ventilated area.
- Select bare ground, stop engine, and allow unit to cool before refueling.
- Save these instructions. Refer to them frequently and use them to instruct others who may use this tool. If you loan someone this tool, loan them these instructions also.

SYMBOLS

The following signal words and meanings are intended to explain the levels of risk associated with this product.

SYMBOL	SIGNAL	MEANING
	DANGER:	Indicates an imminently hazardous situation, which, if not avoided, will result in death or serious injury.
	WARNING:	Indicates a potentially hazardous situation, which, if not avoided, could result in death or serious injury.
	CAUTION:	Indicates a potentially hazardous situation, which, if not avoided, may result in minor or moderate injury.
	CAUTION:	(Without Safety Alert Symbol) Indicates a situation that may result in property damage.

Some of the following symbols may be used on this product. Please study them and learn their meaning. Proper interpretation of these symbols will allow you to operate the product better and safer.

SYMBOL	NAME	EXPLANATION
	Safety Alert Symbol	Indicates a potential personal injury hazard.
	Read the Operator's Manual	To reduce the risk of injury, user must read and understand operator's manual before using this product.
	Wear Eye and Hearing Protection	Always wear eye protection with side shields marked to comply with standards, as well as hearing protection when operating this equipment.
	Vacuum Door	Do not run unit while vacuum door is unsecured.
	Long Hair	Risk of long hair being drawn into air inlet.
	Blower Tubes	Do not run unit without tubes in place.
	Loose Clothing	Risk of loose clothing being drawn into air intake.
	Gasoline and Lubricant	Use unleaded gasoline intended for motor vehicle use with an octane rating of 87 [(R + M) / 2] or higher. This product is powered by a 2-stroke engine and requires pre-mixing gasoline and 2-stroke lubricant.

DESCRIPTION

FIG 1A.

1. Lower vacuum tube
2. Vacuum bag
3. Vacuum tube screw
4. Adaptor
5. Cruise control
6. Throttle trigger
7. Upper vacuum tube
8. Fuel cap
9. Starter grip
10. Choke lever
11. Upper handle
12. On/Off switch
13. Muffler
14. Primer bulb
15. Vacuum handle

FIG 1B

16. Sweeper nozzle
17. Upper blower tube
18. Door tab
19. Inlet cover door
20. High velocity nozzle with leaf scraper

FIG 2

21. Sweeper nozzle
22. Upper blower tube

FIG 3

23. Vacuum bag
24. Adaptor

FIG 4

25. Raised slot
26. Adaptor installed in vacuum bag
27. Raised locking tab

FIG 5

28. Vacuum bag assembly
29. Door tab
30. Vacuum inlet door
31. Vacuum inlet door hinge

FIG 6

32. Vacuum opening
33. Locking tab
34. Screw
35. Vacuum tube assembly
36. Vacuum inlet door

FIG 7

37. Starter grip and rope
38. Quick start label
39. Throttle trigger
40. On/Off switch
41. Choke lever
42. Primer bulb

FIG 9

43. Sweeper nozzle
44. High velocity nozzle

FIG 10

45. Cruise control
46. Throttle trigger

FIG 12

47. Air filter cover
48. Air filter cover knob

FIG 13

49. Air filter cover
50. Air filter

FEATURES

PRODUCT SPECIFICATIONS

Engine Displacement	26cc
Air Velocity:	
MPH / KPH	200 / 320 (with high velocity nozzle)
CFM / M ³ /M	400 / 11 (at housing)
Weight	9.5 lbs / 4.3 kg

KNOW YOUR BLOWER/VACUUM

See Figures 1a - 1b.

The safe use of this product requires an understanding of the information on the tool and in this operator's manual as well as a knowledge of the project you are attempting. Before use of this product, familiarize yourself with all operating features and safety rules.

BLOWER TUBE AND NOZZLES

The blower tube can be assembled and installed on the blower without using any tools.

CRUISE CONTROL

The cruise control feature allows the user to operate the blower without holding the throttle trigger. To slow the engine, simply push the cruise control lever forward.

HIGH VELOCITY NOZZLE WITH WET LEAF SCRAPER

The high velocity nozzle is great for wet sticky leaves. It allows you to scrape wet leaves or debris while operating the blower.

MOTOR

The blower has a powerful 26cc engine with sufficient power to handle tough blowing and vacuuming jobs.

SIMPLE START™

The Simple Start allows for easier and quicker starting.

SWEEPER NOZZLE

The sweeper nozzle allows for more area to be covered during blower operation.

THROTTLE TRIGGER

The blower can be operated at any speed between idle and full throttle.

VACUUM/MULCHER

Converting the blower to a vacuum/mulcher is simple and can be done using a flat head screwdriver.

VACUUM BAG

The vacuum bag attaches to the blower easily by using the vacuum bag adaptor.

VACUUM HANDLE

This feature allows user to perform vacuuming duties comfortably.

VACUUM TUBES

The vacuum tubes can be installed on the blower using a flat head screw driver.

ASSEMBLY

UNPACKING

This product requires assembly.

- Carefully remove the product and any accessories from the box. Make sure that all items listed on the Packing List are included.

WARNING:

Do not use this product if any parts on the Packing List are already assembled to your product when you unpack it. Parts on this list are not assembled to the product by the manufacturer and require customer installation. Use of a product that may have been improperly assembled could result in serious personal injury.

- Inspect the product carefully to make sure no breakage or damage occurred during shipping.
- Do not discard the packing material until you have carefully inspected and satisfactorily operated the product.

- If any parts are damaged or missing, please call Ryobi customer service for assistance.

PACKING LIST

Blower
Upper Blower Tube
Sweeper Nozzle
High Velocity Nozzle
Upper and Lower Vacuum Tubes
Vacuum Tube Screws (2)
Vacuum Bag
Vacuum Bag Adaptor
2-Stroke Engine Lubricant
Operator's Manual

NOTE: Read and remove all hang tags and store with your operator's manual.

ASSEMBLY

WARNING:

If any parts are damaged or missing do not operate this product until the parts are replaced. Using the unit with damaged or missing parts could result in serious personal injury.

WARNING:

Do not attempt to modify this product or create accessories not recommended for use with this product. Any such alteration or modification is misuse and could result in a hazardous condition leading to possible serious personal injury.

WARNING:

To prevent accidental starting that could cause serious personal injury, always disconnect the engine spark plug wire from the spark plug when assembling parts.

ASSEMBLING THE BLOWER TUBES

See Figure 2.

- Align raised tabs on blower housing outlet to the slots on upper tube; slide together and tighten securely by twisting. Check tightness after initial use and retighten if needed.
- Attach desired nozzle (high velocity nozzle or sweeper nozzle) to upper blower tube by aligning raised tabs on upper blower tube; slide together and tighten securely by twisting. Check tightness after initial use and retighten if needed.
- To remove the tubes, rotate the tubes to unlock them and remove from the blower housing outlet.

INSTALLING THE VACUUM BAG

See Figures 3 - 4.

- Remove the nozzle and upper blower tube from the blower by twisting and removing from blower housing outlet.
- Unzip the vacuum bag and place the adaptor inside as shown. Push the vacuum bag adaptor through the

opening opposite the zipper. The wider end of the adaptor will remain on the inside of the vacuum bag when installed properly.

- Align the raised slots on the vacuum bag adaptor with the raised locking tabs on the blower housing outlet; push the bag adaptor onto the housing. Twist to lock into place.
- Rotate the vacuum bag until the shoulder strap is upright.
- Make sure the vacuum bag is zipped and closed before starting the unit.

INSTALLING THE VACUUM TUBES

See Figures 5 - 6.

WARNING:

Rotating impeller blades can cause severe injury. Always stop the engine and ensure impeller blades have stopped rotating before opening the vacuum door or installing/changing tubes. Do not put hands or any other object into the vacuum tubes while they are installed on the unit.

To install the vacuum tubes:

- Secure the upper and lower vacuum tubes together by aligning the raised locking tabs with the raised slots.
- Tap tube assembly on ground until the screw holes in lower tube are in the raised slot of the upper tube. Secure with supplied screws.
- Depress door tab using a flathead screwdriver and open vacuum inlet door.
- Align tabs on housing with tube assembly.
- Tighten screws on upper vacuum tube to secure to blower housing.

To remove the vacuum tubes:

- Loosen screws of the upper vacuum tube by turning counterclockwise.
- Remove the vacuum tube assembly from the blower housing.
- Close the vacuum inlet cover door securely.

OPERATION

WARNING:

Do not allow familiarity with this product to make you careless. Remember that a careless fraction of a second is sufficient to inflict serious injury.

WARNING:

Always wear eye protection with side shields marked to comply with standards, along with hearing protection. Failure to do so could result in objects being thrown into your eyes and other possible serious injuries.

APPLICATIONS

You may use this product for the purposes listed below:

- Clearing leaves and other debris from your lawn
- Keeping decks and driveways free from leaves and pine needles
- Vacuuming leaves from your lawn

MIXING THE FUEL

This product is powered by a 2-Stroke engine and requires premixing gasoline and 2-Stroke oil. The mixture should be at a 50:1 ratio.

NOTE: We recommend you use Ryobi synthetic 2-Stroke lubricant. Only use a quality synthetic 2-Stroke lubricant in your blower to ensure top performance and engine longevity.

TO MIX THE FUEL:

- Use a clean container that is approved for use with gasoline.
- Mix the 2-Stroke engine oil with unleaded gasoline in the container, according to the instructions on the oil package.

This engine is certified to operate on unleaded gasoline intended for automotive use with an octane rating of 87 [(R + M) / 2] or higher. Do not use fuels containing ethanol.

NOTE: Most fuel mixture will stay fresh up to 30 days. DO NOT mix quantities larger than usable in a 30 day period.

2-STROKE FUEL / OIL MIX (50:1)



PETROL

OIL

1 litre

20 cc (20 ml)

FILLING THE TANK

WARNING:

Petrol is extremely flammable and explosive. A fire or explosion from petrol will burn you and others. Always shut off engine before fueling. Never add fuel to a machine with a running or hot engine. Move at least 10m from refueling site before starting engine. Do not smoke and stay away from open flames and sparks. Failure to safely handle fuel could result in serious personal injury.

- Clean the surface around the fuel cap to prevent contamination.
- Loosen the fuel cap slowly by turning counterclockwise.
- Pour the fuel mixture carefully into the tank.
- Clean and inspect the fuel cap gasket before replacing the fuel cap.
- Replace the fuel cap and tighten it by turning it clockwise.
- Wipe spilled fuel from the product.
- Move at least 10m away from refueling area before starting the product.

NOTE: It is normal for smoke to be emitted from a new engine during first use.

WARNING:

Check for fuel leaks. A leaking fuel cap is a fire hazard and must be replaced immediately. If you find any leaks, correct the problem before using the product. Failure to do so could result in a fire that could cause serious personal injury.

OXYGENATED FUELS

DO NOT USE E85 FUEL. IT WILL VOID YOUR WARRANTY.

NOTE: Fuel system damage or performance problems resulting from the use of an oxygenated fuel (ethanol) are not covered under warranty.

STARTING AND STOPPING

See Figure 7.

To start a cold engine:

DO NOT squeeze the throttle trigger until the engine starts and runs.

- Lay the blower/vacuum on a flat, level surface.
- **PRIME** - Press the primer bulb 7 times.

OPERATION

- **SET** the choke lever to the **START** position.
- **PULL** the starter rope with a quick, firm and consistent motion **until the engine starts**.
- Allow engine to warm up for 5-20 seconds, then squeeze the throttle trigger to run.

NOTE: Squeezing the throttle trigger releases the choke lever to the **RUN** position.

To start a warm engine:

DO NOT squeeze the throttle trigger until the engine starts and runs.

PULL the starter rope with a quick, firm and consistent motion **until the engine starts**.

To stop the engine:

Press and hold the switch in the stop “O” position until the engine stops.

OPERATING THE BLOWER

See Figures 8 - 9.

WARNING:

Never run the unit without the blower tubes installed or the vacuum door securely closed. Use of an improperly assembled unit could result in serious personal injury.

- Start the blower. Refer to **Starting and Stopping** earlier in this manual. Hold the blower with the upper handle in your right hand.

WARNING:

Always hold the blower away from your body with the handle in your right hand when operating as a blower, keeping clearance between your body and the product. The muffler side of the blower should be opposite from your body. Any contact with the exhaust housing can result in burns and/or other serious personal injury.

WARNING:

Do not place blower on top of or near loose debris or gravel. Debris may be sucked into blower intake vent resulting in possible damage to the unit and could result in serious personal injury.

- To keep from scattering debris, blow around the outer edges of a debris pile. Never blow directly into the center of a pile.
- Operate power equipment at reasonable hours only - not early in the morning or late at night when people might be disturbed. Comply with the times listed with local authorities.

- To reduce sound levels, limit the number of pieces of equipment used at any one time.
- Conserve water by using power blowers instead of hoses for many lawn and garden applications, including areas such as gutters, screens, patios, grills, porches, and gardens.
- Operate blower at the lowest possible throttle speed to do the job.
- Check your equipment before operation, especially the muffler, air intakes, and air filters.
- Use rakes and brooms to loosen debris before blowing.
- In dusty conditions, slightly dampen surfaces when water is available.
- Watch out for children, pets, open windows, or freshly washed cars, and blow debris safely away.
- Hold blower, as shown in Figure 9, so the air stream can work close to the ground.
- After using blowers or other equipment, **CLEAN UP!** Dispose of debris properly.
- Use the sweeper nozzle for the everyday blowing operation. This nozzle allows for more area to be covered during the blowing operation.
- The high velocity nozzle is specifically designed for wet sticky leaves. It allows you to scrape wet leaves or debris while operating the blower.

CRUISE CONTROL

See Figure 10.

The cruise control can be used to operate the blower without holding the throttle trigger.

To engage the cruise control:

- Pull cruise control lever back towards user, and stop at the desired throttle setting.
- To release the cruise control, push cruise control lever all the way towards the front of unit.

VACUUM OPERATION

See Figure 11.

WARNING:

Never run the unit without the vacuum tubes and vacuum bag installed. Use of an improperly assembled unit could result in serious personal injury.

WARNING:

Keep the muffler and all hot surfaces of the blower/vacuum away from your body. Failure to do so could result in possible serious personal injury.

OPERATION

- Install the vacuum tubes and the bag. Refer to the *ASSEMBLY* section earlier in this manual.
- Start the blower. Refer to **Starting and Stopping** earlier in this manual.
- Place the vacuum bag strap over your right shoulder. Hold the upper handle in your left hand and the vacuum handle in your right hand.
- Move the blower/vacuum from side to side along outer edge of the debris. To avoid clogging, do not place the vacuum tube directly into the debris pile.
- Hold the engine higher than the inlet end of the vacuum tube.
- Always point vacuum tube downhill when working on a hillside.
- To avoid serious injury to the operator or damage to the unit, do not pick up rocks, broken glass, bottles, or other similar objects.
- If the vacuum tubes should clog, stop the engine, ensure impeller blades have stopped spinning, and disconnect the spark plug wire before cleaning out the obstruction.
- Remove the vacuum tubes and clear the debris from the blower fan housing. Remove the bag and clear the tube. A small rod or stick may be required to clear the entire tube length. Ensure that all debris has been cleared before reassembling the vacuum tubes.

MAINTENANCE

WARNING:

When servicing, use only identical replacement parts. Use of any other parts may create a hazard or cause product damage.

WARNING:

Always wear eye protection with side shields marked to comply with standards, along with hearing protection. Failure to do so could result in objects being thrown into your eyes and other possible serious injuries.

WARNING:

Before inspecting, cleaning, or servicing the machine, shut off engine, wait for all moving parts to stop, and disconnect spark plug wire and move it away from spark plug. Failure to follow these instructions can result in serious personal injury or property damage.

GENERAL MAINTENANCE

Avoid using solvents when cleaning plastic parts. Most plastics are susceptible to damage from various types of commercial solvents and may be damaged by their use. Use clean cloths to remove dirt, dust, lubricant, grease, etc.

WARNING:

Do not at any time let brake fluids, gasoline, petroleum-based products, penetrating lubricants, etc., come in contact with plastic parts. Chemicals can damage, weaken or destroy plastic which may result in serious personal injury.

You can often make adjustments and repairs described here. For other repairs, have the blower/vacuum serviced by an authorized service dealer.

CLEANING THE AIR FILTER

See Figure 12 - 13.

A dirty air filter will cause starting difficulty, loss of performance, and shorten the life span of the engine. Check the air filter monthly. For best performance, replace the air filter at least once a year.

- Loosen the air filter cover by turning the knob counterclockwise.
- Remove the air filter (item 50).
- Clean the foam filter element with warm soapy water. Rinse and let dry.
NOTE: If the foam filter element is damaged, it should be replaced.
- Apply a light coat of engine oil to the foam filter element, then squeeze it out.
- Reinstall the air filter.
NOTE: Make sure the filter is seated properly inside the cover. Installing the filter incorrectly will allow dirt to enter the engine, causing rapid engine wear.
- Reinstall the cover and tighten knob to secure.

CLEANING THE EXHAUST PORT, MUFFLER AND SPARK ARRESTOR

NOTE: Depending on the type of fuel used, the type and amount of lubricant used, and/or your operating conditions, the exhaust port, muffler, and/or spark arrestor screen may become blocked with carbon deposits. If you notice a power loss with your petrol powered tool, you may need to remove these deposits to restore performance. We highly recommend that only qualified service technicians perform this service.

MAINTENANCE

The spark arrestor must be cleaned or replaced every 50 hours or yearly to ensure proper performance of your product. Spark arrestors may be in different locations depending on the model purchased. Please contact your nearest service dealer for the location of the spark arrestor for your model.

WARNING:

To avoid a fire hazard, never run the blower/vacuum without the spark arrestor in place.

VACUUM BAG

A dirty bag will reduce performance. To clean the bag, turn it inside out and shake. Wash the bag in soapy water at least once a year. To obtain a replacement bag, see **How to Order Replacement Parts** on the back page of this manual.

FUEL CAP

WARNING:

A leaking fuel cap is a fire hazard and must be replaced immediately.

The fuel cap contains a sealing gasket and a check valve to ventilate built up fuel gasses. A clogged check valve will cause poor engine performance. If performance improves when the fuel cap is loosened, the check valve may be faulty. Replace fuel cap if required.

The fuel supplied to the engine is passed through a filter to remove any contaminants from entering the engine. Contaminants in the fuel can cause poor performance and damage to the engine.

The fuel filter is a non-serviceable item and if needed should be replaced by a **AUTHORISED SERVICE CENTRE**.

SPARK PLUG REPLACEMENT

This engine uses a Champion RCJ-6Y or NGK BPMR7A spark plug with .025 in. electrode gap. Use an exact replacement and replace annually.

STORING THE PRODUCT

- Clean all foreign material from the product. Store idle unit indoors in a dry, well-ventilated area that is inaccessible to children. Keep away from corrosive agents such as garden chemicals and de-icing salts.
- Abide by all ISO and local regulations for the safe storage and handling of petrol.

When storing 1 month or longer:

- Drain all fuel from tank into a container approved for gasoline. Run engine until it stops.

TROUBLESHOOTING

IF THESE SOLUTIONS DO NOT SOLVE THE PROBLEM, CONTACT YOUR AUTHORIZED SERVICING DEALER.

PROBLEM	CAUSE	REMEDY
Engine fails to start.	No fuel in tank. Spark plug is fouled. Spark plug is broken. (cracked porcelain or electrodes broken) Ignition lead wire shorted, broken, or disconnected from spark plug. Ignition inoperative.	Fill tank. Replace spark plug. Replace spark plug. Replace lead wire or attach to spark plug. Contact authorised service center.
Engine hard to start.	Water in gasoline or stale fuel mixture. Too much lubricant in fuel mixture. Engine is under or over choked. Weak spark at spark plug.	Drain entire system and refill with fresh fuel. Drain and refill with correct mixture. Adjust choke as necessary. Contact authorised service center.
Engine lacks power.	Air filter clogged.	Clean air filter. Refer to Cleaning the Air Filter Screen earlier in this manual.
Engine overheats.	Insufficient lubricant in fuel mixture.	Mix fuel as described in starting instructions.

LIMITED WARRANTY

TTI warrants this outdoor product to be free of defects in material and workmanship for 24 months from the date of purchase by the original purchaser, subject to the limitations below. Please keep your invoice as proof of date of purchase.

This warranty is only applicable where the product is used for personal and non-commercial purposes. This warranty does not cover damage or liability caused by / due to misuse, abuse, accidental or intentional acts by user, improper handling, unreasonable use, negligence, failure by end user to follow operating procedures outlined in the user's manual, attempted repair by non-qualified professional, unauthorized repair, modification, or use of accessories and/or attachments not specifically recommended by authorized party.

This warranty does not cover belts, brushes, bags, bulbs or any part which ordinary wear and tear results in required replacement during warranty period. Unless specifically provided under applicable law, this warranty does not cover transportation cost or consumable items such as fuses.

This limited warranty is void if the product's original identification (trade mark, serial number, etc.) markings have been defaced, altered or removed or if product is not purchased from an authorized reseller or if product is sold AS IS and / or WITH ALL FAULTS.

Where permitted, the provisions of this limited warranty are in lieu of any other written warranty, whether express or implied, written or oral, including any warranty of MERCHANTABILITY OR FITNESS FOR A PARTICULAR PURPOSE. IN NO EVENT SHALL WE BE LIABLE FOR SPECIAL, INCIDENTAL, CONSEQUENTIAL OR INCIDENTAL DAMAGES. OUR MAXIMUM LIABILITY SHALL NOT EXCEED THE ACTUAL PURCHASE PRICE PAID BY YOU FOR THE PRODUCT.

This warranty is valid only in the European Union, Australia and New Zealand. Outside these areas, please contact your authorized Ryobi dealer to determine if another warranty applies.

TECHTRONIC INDUSTRIES EMEA

Medina House,
Fieldhouse Lane, Marlow,
Buckinghamshire,
SL7 1TB,
UNITED KINGDOM

TECHTRONIC INDUSTRIES EMEA

Medina House,
Fieldhouse Lane, Marlow,
Buckinghamshire,
SL7 1TB,
UNITED KINGDOM

RYOBI TECHNOLOGIES (UK) LIMITED.

Medina House,
Fieldhouse Lane, Marlow,
Buckinghamshire,
SL7 1TB,
UNITED KINGDOM
Tel: + 44 (0) 1628 894400
Fax: + 44 (0) 1628 894401
Technical Helpline : + 44 (0) 800 389 0305

TECHTRONIC INDUSTRIES FRANCE SAS

Immeuble Le Grand Roissy
Z.A. du Gué - 35 rue de Guivry
77990 LE MESNIL AMELOT FRANCE
Phone: + 33(0)1 60 94 69 70
Fax: + 33(0)1 60 94 69 79

RYOBI BELGIUM

Avenue des Pâquerettes, 55
Zoning artisanal - bâtiment 5
B - 1410 Waterloo
BELGIQUE
Tel : + 32(0) 2357 8140
Fax : + 32(0) 2357 8149

TTI ITALIA SRL

Via Fratelli Gracchi, 39
20092 Cinisello Balsamo (MI)
Italia
Tel : + 39(0) 5923 8408
Fax : + 39(0) 5924 6960

TECHTRONIC INDUSTRIES IBERIA S.L

Av. De la Industria,52
Coslada – Madrid – España
Tel: 91 485 12 10

**TECHTRONIC INDUSTRIES SOUTH AFRICA
CO. (PTY) LTD**

P.O Box 83888, South Hills, Johannesburg, 2136
South Africa

TECHTRONIC INDUSTRIES (ASIA) CO., LTD.

24/F, CDW Building,
388 Castle Peak Road,
Tsuen Wan, Hong Kong.
Tel : + 852 2402 6888

RYOBI TECHNOLOGIES GMBH

Itterpark 4
D-40724 Hilden
DEUTSCHLAND
Tel: + 49 (0) 2103 2958-0
Fax: + 49 (0) 2103 2958-29

RYOBI TECHNOLOGIES GMBH

Vertriebsbüro Österreich
Schnitzgasse 13
A-8605 Kapfenberg
Tel.: + 43 (0) 3862 23590-0
Fax: + 43 (0) 3862 23590-25

TECHTRONIC INDUSTRIES AUSTRALIA PTY LIMITED.

Building B, Rosehill Industrial Estate,
3 Shirley Street,
Rosehill NSW 2142
AUSTRALIA
Tel: (02) 8892 1800 or 1300 361 505
Fax: 1800 807 993

TECHTRONIC INDUSTRIES (NZ) LIMITED.

27 Clemow Drive, Mt Wellington
PO Box 12-806, Penrose, Auckland
NEW ZEALAND
Tel: + 64 (0) 9 573 0230
Free Call: +64 0800 279 624
Fax: + 64 (0) 9 573 0231

A&M MIDDLE EAST FZCO

P.O.Box 61254
Jedel Ali, Dubai,
UNITED ARAB EMIRATES
Tel.: + 9714 8861399
Fax: + 9714 8861400

TECHTRONIC INDUSTRIES DENMARK APS

Stamholmen 147, 4.
DK-2650 Hvidovre
Denmark
Tlf 43 56 55 55, Fax 43 56 55 56
E-mail: kundeservice@tti-emea.com

TECHTRONIC INDUSTRIES NORWAY AS

Tlf.: 800 12 493, Faks: 800 12 492
E-mail: kundetjeneste@tti-emea.com

TECHTRONIC INDUSTRIES SWEDEN AB

Tel (+46) 08 24 60 30. fax (+46) 08 24 60 31.
E-mail: kundtjanst@tti-emea.com

TECHTRONIC INDUSTRIES FINLAND OY

Tel. 0800 1 09000, Fax 0800 1 09001
Email: asiakaspalvelu@tti-emea.com

Machine: BLOWER / VACUUM

Name of company: Homelite Far East Co., Ltd.
Address: 24/F, CDW Building,
388 Castle Peak Road,
Tsuen Wan, Hong Kong.

Type: RBV26

Name/Title: Andrew Eyre
Vice President, Engineering

Signature:



11/2009